

Eddystone

PROFESSIONAL GRADE UHF RECEIVER

MODEL 1990S

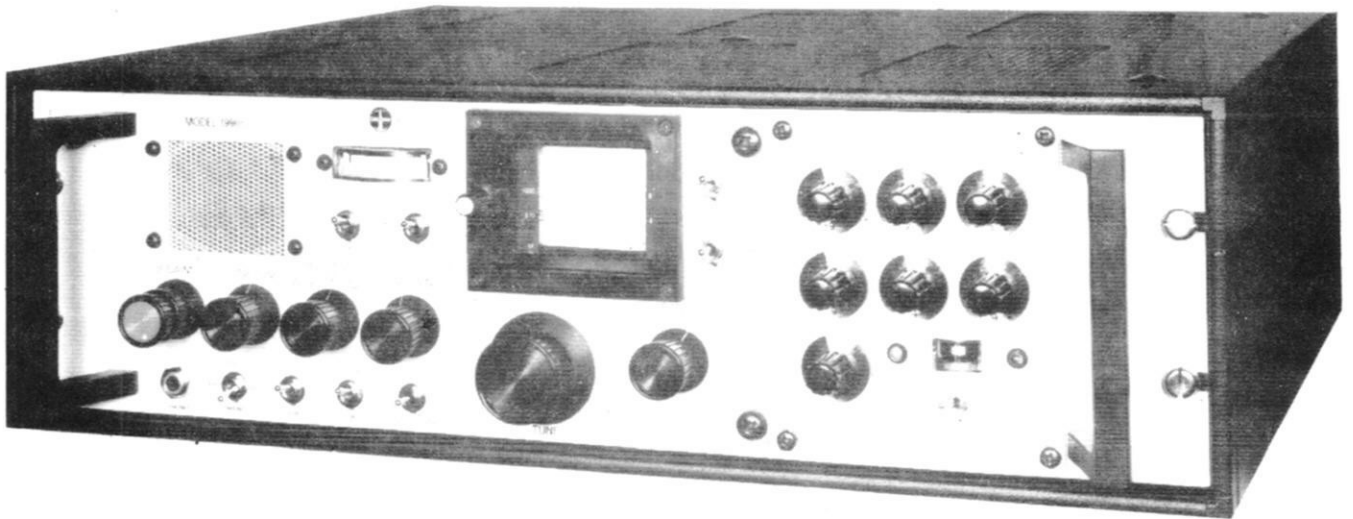

Manufactured in England by



EDDYSTONE RADIO LIMITED

MEMBER OF MARCONI COMMUNICATION SYSTEMS LIMITED
ALVECHURCH ROAD, BIRMINGHAM B31 3PP

Telephone: 021-475 2231

Telex: 337081



ISSUE NUMBER 1 MAY 1979

PRINTED IN ENGLAND

CONTENTS

SECTION 1	INTRODUCTION	Page 1- 1
SECTION 2	INSTALLATION	Page 2- 1
SECTION 3	OPERATING INSTRUCTIONS	Page 3- 1
SECTION 4	TECHNICAL DATA CIRCUIT DESCRIPTION	Page 4- 1 Page 4- 5
SECTION 5	MAINTENANCE FAULT DIAGNOSIS PERFORMANCE TESTING VOLTAGE ANALYSIS TABLES	Page 5- 1 Page 5- 6 Page 5-10 Page 5-20
SECTION 6	COMPONENTS LIST	Page 6- 1

APPENDICES

APPENDIX A	AMENDMENT DATA) BOUND
APPENDIX B	MODEL VARIANTS) AT REAR

ILLUSTRATIONS

	MAIN CIRCUIT DIAGRAM	BOUND AT REAR
FIGURE 2-1	DIMENSION OF RECEIVER	Page 2- 2
FIGURE 2-2	REAR PANEL VIEW	Page 2- 4
FIGURE 2-3	TERMINATIONS ON DC CONNECTOR	Page 2- 5
FIGURE 2-4	ANCILLARIES CONNECTOR	Page 2- 7
FIGURE 3-1	FRONT VIEW OF RECEIVER	Page 3- 1
FIGURE 5-1	INTERNAL VIEW (TOP)	Page 5-23
FIGURE 5-2	INTERNAL VIEW (BOTTOM)	Page 5-24

P.C.B. LAYOUTS

(2)	440- 800MHz TUNER UNIT	Page 5-25
(3)	800-1000MHz TUNER UNIT	Page 5-25
* (4)	(REFER TO SYNCHRONISER HANDBOOK)	N/A
(5)	OSCILLATOR DIVIDE BY 10 MODULE	Page 5-25

CONTENTS

P.C.B. LAYOUTS

(6)	SELECTIVITY MODULE	Page 5-26
(7)	FM MODULE	Page 5-26
(8)	AM DETECTOR & VIDEO MODULE	Page 5-27
(9)	AM IF AMPLIFIER MODULE	Page 5-27
(10)	CRYSTAL CALIBRATOR(S) UNIT	Page 5-28
(11)	SYNCHRONISER/AFC AMPLIFIER BOARD	Page 5-28
(12)	IF AGC MUTING MODULE	Page 5-28
(13)	24V SWITCHED MODE BOARD	Page 5-29
(14)	AUDIO BOARD	Page 5-29
* (15)	(NOT APPLICABLE)	N/A
(16)	VOLTAGE INVERTOR UNIT	Page 5-30
(17)	SYNCHRONISER INVERT BOARD	Page 5-30

Section 1

INTRODUCTION

General Description

The Eddystone Model 1990S is a professional grade UHF receiver primarily intended for communications and laboratory applications. The frequency range covered is 440-1000MHz and provision is made for reception of AM, FM and PULSE transmissions.

Operating voltage can be taken from any standard 40-60Hz AC supply in the range 100/130V - 200/260V; or 12V DC with negative earth. The equipment is supplied either for installation in standard 483mm (19 inch) racking or with a cabinet ready for bench mounting. Accessories available include a plinth loudspeaker, special aerial systems, a seven digit readout frequency counter Model 1535/2 and a matching panoramic display unit Model 1061B.

Guarantee

All 1990S receivers are suitable for continuous use under arduous operating conditions and should require very little routine maintenance over long periods of operation. With the exception of the semi-conductors, all components are guaranteed by the Manufacturer for a period of one year from the date of purchase. The semi-conductors are all covered by a separate guarantee.

Servicing

Spares for user servicing can be supplied and helpful advice will be freely given when required. Any enquiries relating to service matters should be directed to the "Sales and Service Department", at our usual address.

Should major servicing become necessary, the receiver can, by prior arrangement, be returned to the Manufacturer for attention. Extreme care should be taken to ensure that the equipment is well protected against possible damage during transit.

INSTALLATION

ASSEMBLY INSTRUCTIONS

Accessories Kit

A kit of accessories is supplied with the receiver. The contents of the kit should be checked against Table 2.1 at the end of this Section.

Rack-mounting Receivers

Rack-mounting versions can be installed directly in 483mm (19in.) racks, using four $\frac{1}{2}$ in. BSF chromium-plated screws. Suitable screws are Eddystone Ref. 40A-330. Plain washers Ref. 27E-57 should be fitted to prevent damage to the panel finish. Fixing slots conform to standard with centre spacing of 57.2mm (2.25in.). Overall dimensions of the standard rack-mounting receiver are shown in Fig. 2.1 - E & F.

Bench-mounting Receivers

Four mounting feet are included with the Accessories Kit. These should be fixed to the bottom corners of the cabinet using the four 2BA screws supplied. Overall dimensions of the receiver, in cabinet fitted with standard mounting feet, are shown in Fig. 2.1 - B.

Conversion of Mounting Styles

Rack-mounting receivers may easily be converted to bench-mounting and vice-versa. Accessories for this purpose are listed in Table 2.2 at the end of this section. Note that dust covers must be removed when fitting a rack-mounting receiver into a standard cabinet.

Anti-vibration Mountings

These are available to order for bench-mounting receivers. They are fitted instead of standard mounting feet, using the same fixing holes. Overall dimensions of the receiver in cabinet fitted with anti-vibration mountings, are shown in Fig. 2.1 - A. To fit the anti-vibration mountings proceed as follows:-

1. Invert the receiver.
2. Place the large neoprene washers over the fixing holes with stepped faces uppermost.
3. Lower the channel-shaped mountings onto the washers, keeping the fixing flanges towards the outside of the receiver. Ensure that the steps on the washers locate with the holes in the channel mountings.
4. Place the small neoprene washers on the inside of the channel mountings. Secure the mountings with the 2BA screws, fitted with brass washers.

- Fix the mountings to the bench top with suitable screws; alternatively the mountings may be bonded to the bench if this is of metal construction.

Plinth Loudspeaker Unit

This is supplied to order for bench-mounting receivers. Overall dimensions of the receiver fitted with the Plinth Loudspeaker Unit are shown in Fig. 2.1 - C & D. The Unit should be secured to the underside of the cabinet with 2BA screws, using the inner group of fixing holes provided.

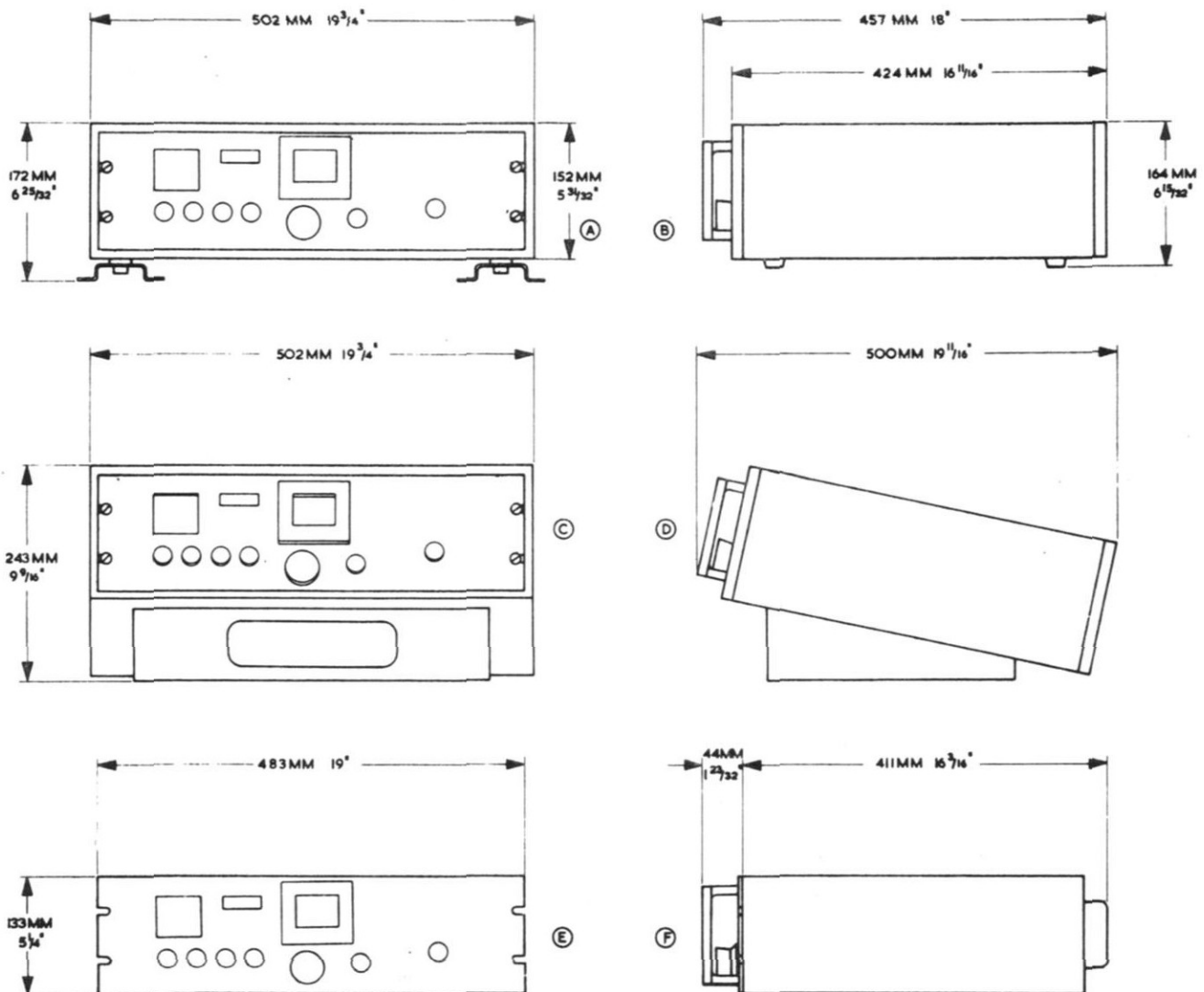

- A Frontal dimensions of Receiver in Cabinet 8866P mounted on Shock-Absorbent Mountings LP2817/1.
- B Side elevation of Receiver in Cabinet 8866P fitted with standard mounting feet.
- C & D Receiver in Cabinet 8866P on Plinth Loudspeaker Unit Cat. No. 989.
- E & F Standard Rack-Mounting Receiver.

Fig. 2.1 Dimensions of Receiver in all mounting styles.

Power Supplies

The receiver must be disconnected from the supply before removing covers or making adjustments to the power circuits.

The receiver may be powered from any standard 40-60Hz AC supply in the range 100/130V or 200/260V. Alternatively, a 12V DC supply with negative earth can be used. Change-over from one type of supply to the other is effected by means of a front panel mounted switch.

Before connecting the receiver to either form of supply source, it is essential to note the information given below.

AC Supplies

Standard receivers as despatched from the Factory are suitable for 240V operation. Other voltages may be specified at the time of ordering, in which case a label is attached to the rear of the receiver, indicating the voltage to be used.

The receiver utilizes a toroidal wound mains transformer with primary voltage tapings. The primary tapings can be easily adjusted to suit any standard AC supply by means of the external mains voltage setting switch located on the rear panel. The mains adjustment switch can be operated with a wide blade screwdriver, or with a suitable coin-shaped instrument.

NOTE! It is essential to disconnect the receiver from the mains supply prior to making primary voltage adjustments.

AC Fuse Rating

105/130V :: 1 Amp (Time-lag)
210/260V :: 0.5 Amp (Time-lag)

DC Supplies

A 12V supply source is required, which can be derived from a battery or other suitable source. The current consumption from a 12V DC supply is of the order of 3 AMPS.

NOTE: The negative pole of the DC supply is connected directly to the receiver chassis which is earthed.

DC Fuse Rating

The DC fuse is rated at 5A and spare fuses are supplied with the Accessory Kit.

EXTERNAL CONNECTIONS

General

With the exception of the telephone headset, all external connections are made at the rear of the receiver. Appropriate connectors are included in the Accessory Kit. A rear view of the receiver is shown at Fig. 2-2.

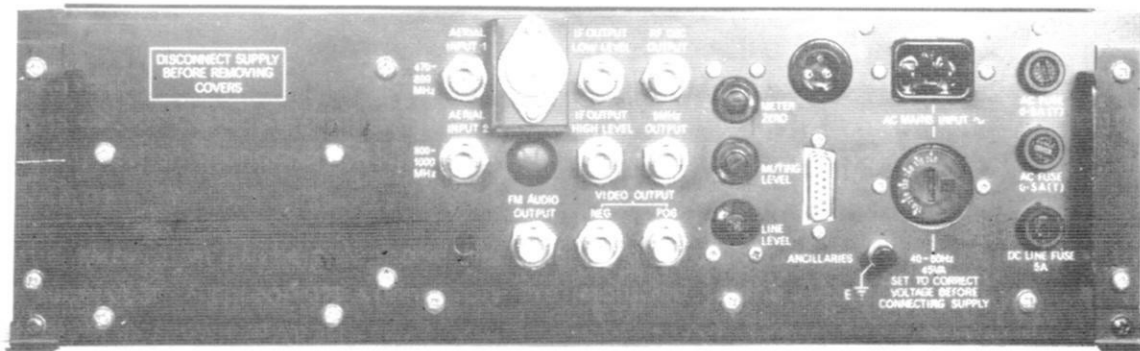

AC Mains Input

The AC supply connector is fitted with approximately 2 metres (78 inches) of 3 core cable which is colour coded in accordance with the current European Standard and generally complies with British Standard BS415, viz:-

LINE	::	BROWN
NEUTRAL	::	BLUE
EARTH	::	GREEN/YELLOW

NOTE: If the colours of the wires in the mains lead of this apparatus do not correspond with the coloured markings identifying the terminals in your AC mains source connector (or mains plug) proceed as follows:-

1. The GREEN/YELLOW wire must be connected to the plug terminal marked "E" or " \perp " coloured GREEN or GREEN/YELLOW.

2. The BLUE wire must be connected to the plug terminal marked "N" or coloured either BLUE or BLACK.
3. The BROWN wire must be connected to the plug terminal marked "L" or coloured either BROWN or RED.

DC Input

The DC supply connections are clearly illustrated in Fig. 2-3 below.



Fig. 2-3 Terminations on DC Supply Connector (viewed on wiring side).

Aerial Input 1

This socket is for use at frequencies in the range 440MHz to 800MHz. The input impedance is 50/75Ω unbalanced. Connection is by means of a BNC bayonet-lock co-axial connector.

Aerial Input 2

This socket is for use at frequencies in the range 800MHz to 1000MHz. The input impedance is 50/75Ω unbalanced. Connection is by means of a BNC bayonet-lock co-axial connector.

Earth Terminal

When installing a rack-mounted receiver, this terminal should be bonded to the rack. If the receiver is housed in a cabinet, the terminal should be connected to the supply earth.

IF Output Low Level

The low level IF socket provides a signal output at the intermediate frequency of 36.5MHz suitable for driving ancillary equipment. The output level is of the order of 15μV into 50Ω for an input of 15μV at the aerial. Connection is by means of a BNC bayonet-lock co-axial connector.

When required to drive the Eddystone Model 1061B panoramic display unit, a converter is available to change the 36.5MHz IF output to 21.4MHz.

IF Output High Level

The high level IF socket serves the same purpose as the low level IF socket. The output level is of the order of 50mV into 50Ω for an input of 15μV at the aerial. The bandwidth is restricted to that of the IF selectivity position in use. Connection is by means of a BNC bayonet-lock co-axial connector.

Oscillator Output

This socket provides an output at the oscillator frequency of the relevant tuner head in use; the oscillator frequency appearing at this socket is divided by 10 to enable the use of a frequency counter. The division by 10 means that it is necessary to provide an offset frequency at the counter of -3.65MHz in order to obtain signal frequency readout. Connection is by means of a BNC bayonet-lock co-axial connector and the respective lead should be terminated into 50Ω.

Standard Frequency Output

This socket provides a 5MHz standard frequency output derived directly from the synchroniser standard. Connection is by means of a BNC bayonet-lock co-axial connector.

Video Output

Two sockets are provided (BNC bayonet-lock co-axial connectors) giving separate positive and negative outputs of 1V p.p. into 50Ω.

FM Output

The BNC bayonet-lock co-axial connector provides an FM audio output taken directly from the buffer stage transistor (7TR3) following the FM discriminator.

Ancillaries

A small 15-way connector is used for the following ancillary circuits:-

- a) External Loudspeaker
- b) Line Audio
- c) Muting Indication
- d) 12V DC Supply for Ancillaries.

The relevant connection data for each ancillary circuit listed above is clearly illustrated in Fig. 2-4 (a) to (d) respectively.

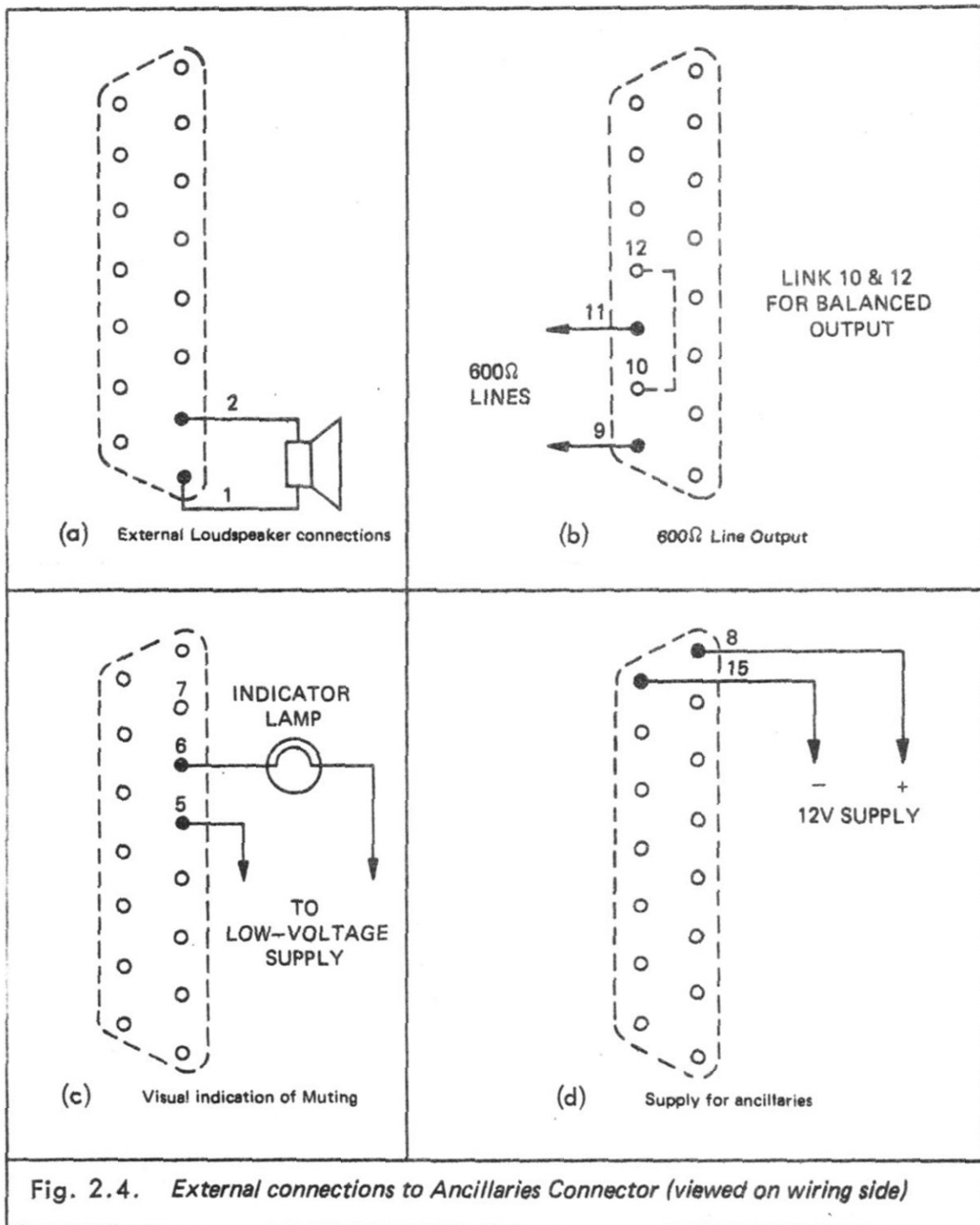

Fig. 2.4. External connections to Ancillaries Connector (viewed on wiring side)

Referring to Fig. 2-4, the relevant details are as follows:-

External Loudspeaker : : Fig. 2-4 (a)

Connect to pins 1 and 2 (earth). Rated output power of 1.5W will be obtained when using a loudspeaker of 3Ω impedance (e.g. Eddystone Cat. No. 935 or 989). A loudspeaker of higher impedance can be used, but the output power will be reduced accordingly.

Line Audio : : Fig. 2-4 (b)

Connect to pins 9 and 11. If a balanced output is required, link pins 10 and 12 (earth). The output, matched to 600Ω lines is 20mW maximum, adjustable by means of a pre-set control at the rear of the receiver.

Muting Indication : : Fig. 2-4 (c)

Audio or visual indication of muting can be provided with the aid of a single-pole change-over relay contact which is connected inside the receiver across pins 5, 6 (common) and 7. The contact across pins 6 and 7 is normally closed and changes over to bridge pins 5 and 6 when the muting circuit operates. The illustration at Fig. 2-4 (c) gives a simple circuit for visual indication of the mute condition. A separate low voltage supply is required. The indicator lamp illuminates when the receiver output is muted.

12V Supply for Ancillaries : : Fig. 2-4 (d)

This DC supply is derived from the power supply unit in the receiver. The current drain should not exceed 30mA (approximately). Note that the negative pole of the supply (pin 15) is connected to the receiver chassis, which is earthed.

TABLE 2-1 CONTENTS OF ACCESSORIES KIT SUPPLIED WITH RECEIVER

Qty	Description	Part No.
4	*Cabinet Mounting Feet (complete with 4 x 2BA screws)	7132P
9	BNC Bayonet-lock co-axial Plugs (for aerial I/P etc)	8012P
1	AC Supply Connector (complete with 3-core cable)	D4815
1	DC Supply Connector	8855P
1	Ancillaries Connector, 15-way (complete with cover)	7771P
1	Telephone Plug	6567P
1	Spare Dial Lamp (12V, 1W, 5mm, wire-ended)	8448P
2	**Spare Fuses : 0.5A (Time-lag)	9714P
1	Spare Fuse : 5A rating	7814P
1	Trimming Tool	8451P
1	Trimming Tool	8333P
1	Box Spanner (for control knobs)	9057P
1	Spring Extractor	9284P

NOTES:-

- *Not supplied for rack-mounting receiver.
- **2 x 1A Time-lag Fuses are supplied when the receiver is despatched adjusted for 100/130V operation.
1A Time-lag Fuse Part No. 9816P.

TABLE 2-2 LIST OF ADDITIONAL ACCESSORIES AVAILABLE TO ORDER

Description	Part No.
Anti-vibration Mounting Kit (supplied unassembled)	LP2817/1
Plinth Loudspeaker Unit	Cat. 989
Cabinet Loudspeaker Unit	Cat. 935
Telephone Headset	LP3242
Telephone Headset	LP3301
Standard Receiver Cabinet (for converting rack-mounting to bench-mounting style)	8866P
IF Converter (36.5MHz to 21.4MHz)	LP3674

OPERATING INSTRUCTIONS

Control Functions

The illustration at Fig. 3-1 below shows the front view of the standard 1990S Receiver complete with synchroniser unit. The rear view of the Receiver is shown at Fig. 2-2 (see Installation).

The controls referred to in this section are clearly shown in the above mentioned illustrations.

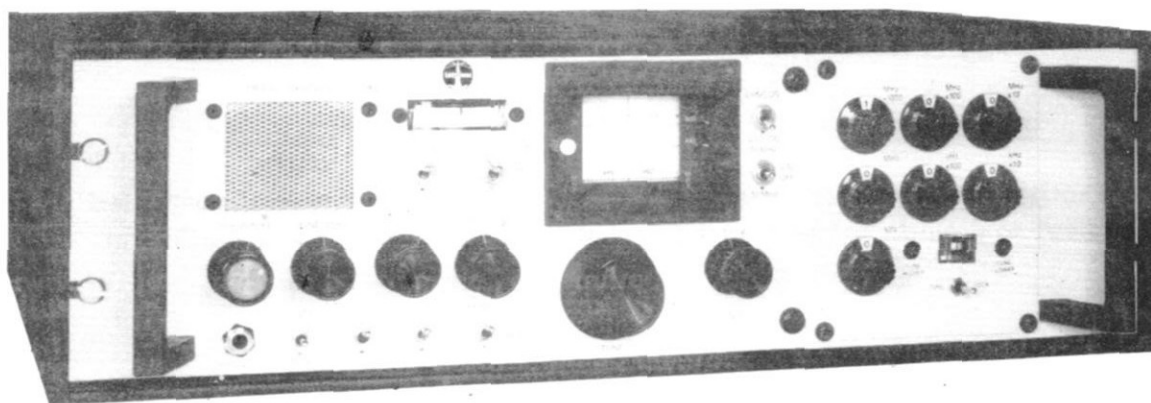

Fig. 3-1. Front View of Receiver showing panel controls.

FRONT PANEL CONTROLS:-

AF Gain

Adjusts the level of audio output of the internal loudspeaker, the external loudspeaker, and/or telephones or headset.

AM-FM

This switch selects the AM or FM mode, as required.

AFC

When the switch is in the down-position, the Automatic Frequency Control circuit is brought into operation. The AFC circuitry stabilises the frequency setting of the Variable Frequency Oscillator. When set to the up-position (SYNC ON) the switch selects the synchroniser control circuit.

Batt-Supply Off-Mains

This three-position toggle switch should be set to BATT in order to operate the Receiver from a suitable low-voltage DC or battery supply.

The switch is set to MAINS for operation from AC Supplies.

When set to the central position (SUPPLY OFF) the Receiver is inoperative.

CAL ADJ

This control, which is located on the left-hand side of the tuning scale escutcheon, moves the cursor relative to the main tuning scale for calibration purposes.

10MHz-Cal Off-50MHz

This three-position toggle switch (central OFF position) selects a crystal controlled oscillator (modulated) to provide calibration markers at the frequency intervals indicated.

Fine-Tune

Provides fine control of tuning for close adjustment.

NOTE: : Scale calibration is correct when the fine tune control is set to the mid-scale position.

IF Gain

Controls the gain of the Intermediate Frequency amplifier when the Automatic Gain Control is not in use (AGC switch set to MANUAL position).

LS-On

When set to the down position (ON) the switch brings the internal loudspeaker into operation.

Manual-AGC Short-AGC Long

When the switch is set to the MANUAL position, the gain of the RF and IF stages can be controlled by the Operator. In the AGC SHORT and AGC LONG positions, Automatic Gain Control is applied.

Meter

The three-position toggle switch functions as follows:-

When set to the (up) RF position, the meter will indicate the carrier level. When set to the (central) FM position, the meter functions as a tuning indicator. Line audio level is indicated on the meter when the switch is set to the (down) AF position.

Muting

When switched to the (down) ON position, the output of the Receiver is muted in the absence of a signal.

Range

The two-position rotary switch selects the tuning range required.

RF Gain

Controls the gain of the Radio Frequency amplifier when the Automatic Gain Control is not in use (AGC switch set to MANUAL position).

Selectivity

The three-position rotary switch functions as follows:-

The standard bandwidths provided are 5MHz in the WIDE position and 400kHz in the N1 position.

The N2 position is only used when an additional filter has been fitted to provide a narrower bandwidth.

Tune

The rotary action control moves the main tuning scale relative to the cursor. A flywheel drive is incorporated to facilitate rapid frequency changes.

Tune Lock (* See NOTE at page 3-9).

This switch is located on the Frequency Synchroniser Unit front panel. When set to the TUNE position, the Receiver can be tuned normally throughout the frequency range. When set to the LOCK position, the Receiver variable frequency oscillator (VFO) is locked to the frequency setting of the Synchroniser Unit.

REAR PANEL CONTROLS:-

Line Level

Used to pre-set the audio level into 600Ω lines.

Meter Zero

Used to initially set the front panel mounted Meter to zero when RF indication is selected.

Muting Level

Pre-sets the threshold level of noise at which muting occurs.

OPERATING PROCEDURES

Prior to putting the Receiver into operation, ensure that the Installation procedures set down in Section 2 have been correctly carried out.

For ease of reference, the operating instructions given here are divided into the following sub-headings:-

- (A) INITIAL SETTING OF CONTROLS : : These instructions apply to all modes of reception.
- (B) OPERATING PROCEDURE.
- (C) GENERAL NOTES ON OPERATING PROCEDURE.
- (D) ANCILLARY EQUIPMENT : : Operation of the receiver in conjunction with ancillary equipment.

(A) INITIAL SETTING OF CONTROLS

Set the controls as follows:-

- (1) SUPPLY Switch to BATT or MAINS as required.
- (2) MUTING Switch to the "OFF" position.
- (3) MANUAL/AGC Switch to "AGC SHORT".
- (4) RF GAIN control to mid-position.
- (5) IF GAIN control to mid-position.
- (6) SELECTIVITY Switch to "N1" position.

- (7) AF GAIN control to mid-position.
- (8) LS Switch to "ON" position.
- (9) AFC Switch to "SYNC" position and TUNE/LOCK Switch to "TUNE" position.
- (10) CAL ADJ control to mid-position.
- (11) FINE TUNE control to mid-position.
- (12) CAL Switch to "CAL OFF".

Controls not listed above should be adjusted in accordance with the following operating procedures.

(B) OPERATING PROCEDURE

It is essential to read the procedures for AM reception first, as the majority of these procedures are also applicable for the reception of FM.

TO RECEIVE AN AM TRANSMISSION : : Initially set the controls as described at (A) above and then proceed as follows:-

- (1) Set the AM/FM Switch to AM.
- (2) Set the METER Switch to RF.
- (3) Check that the AFC Switch has been set to SYNC and that the TUNE/LOCK Switch is in the TUNE position as described at (A) above.
- (4) Select TUNING RANGE 1 or 2 as required.
- (5) TUNING : : Two methods of operation will be described.

When the Signal Frequency is known precisely;

- a) Adjust the tuning selection controls on the Frequency Synchroniser Unit so that the exact readout of signal frequency is obtained.
- b) Tune the Receiver to the selected signal frequency: Two LEDs located on the Synchroniser front panel will indicate "TUNE HIGHER" or "TUNE LOWER" as necessary when the Receiver TUNE control is adjusted, until the main scale setting is correct, whereupon the LEDs will flash alternately thus indicating the correct tune state.
- c) When the "TUNE HIGHER" and "TUNE LOWER" LEDs indicate the correct state of tune (alternate flashing) set the TUNE/LOCK Switch to the LOCK position. The Synchroniser Unit will now hold the Receiver at the desired signal frequency as set on the controls.

When the Signal Frequency is not known precisely;

- a) Tune the Receiver to the desired signal, using the TUNE control.
- b) Set the tuning selection controls on the Frequency Synchroniser Unit to give the same frequency readout as that of the main tuning scale. Slight adjustment of the SYNCHRONISER controls may be necessary to obtain the correct state of tune, as indicated

by the alternate flashing of the "TUNE HIGHER"/"TUNE LOWER" LEDs. When the LEDs flash alternately the Synchroniser Unit will be tuned to the same frequency as the Receiver. Maximum accuracy is ± 1 kHz; final adjustment should be made using the Receiver tuning meter for reference.

- c) Set the TUNE/LOCK Switch to the "LOCK" position. The Synchroniser will now hold the Receiver at the required signal frequency.
- d) NOTE : : In the above procedures, when switching to the "LOCK" position, there will be a short delay period during which the Synchroniser takes control of the Variable Frequency Oscillator. (* See NOTE at page 3-9).
- e) Should the Receiver go off-tune when the TUNE/LOCK Switch is set to the "LOCK" position (with due reference to (d) above) this indicates that the Synchroniser is not set to the exact signal frequency, and therefore requires more careful adjustment. An indication of the degree of synchronism between the Receiver and the Synchroniser is provided by the meter situated on the Synchroniser front panel (between the TUNE HIGHER/TUNE LOWER LED indicators). When the TUNE/LOCK Switch is in the "LOCK" position, the meter pointer will rest at centre scale if the Synchroniser is tuned exactly to the same frequency of the Receiver.

(6) SELECTIVITY

Selectivity can be decreased by setting the Selectivity Switch to the "WIDE" position. The spare position on the Selectivity Switch (designated "N2") may be used if an additional filter has been installed, to provide a narrower bandwidth.

(7) AF GAIN

Adjust the AF Gain control to give the required level of audio output.

(8) RF GAIN and IF GAIN

These controls provide an alternative to Automatic Gain Control. The manual controls will only function when the MANUAL/AGC Switch is set to "MANUAL". The controls should be adjusted to suit reception conditions.

NOTE : : Care should be taken to avoid setting the RF/IF Gain controls too high, otherwise the associated circuits may be overloaded.

(9) AGC; AFC and MUTING

For information concerning the use of these controls, refer to (C) GENERAL NOTES ON OPERATING PROCEDURE (see below).

TO RECEIVE AN FM TRANSMISSION : : Initially set the controls as described at (A) above and then proceed as follows:-

- (1) Set the AM/FM Switch to FM.
- (2) Set the METER Switch to FM.
- (3) Set the TUNE/LOCK Switch to TUNE.
- (4) Select TUNING RANGE 1 or 2 as required.
- (5) TUNING : : As applicable for AM reception except for the following points:-
 - a) In the FM Mode, the Receiver panel meter serves as a tuning indicator. Meter deflection from the centre scale is a measure of the degree of off-tuning; correct tuning on FM signals is obtained when the meter pointer lies at the centre of the scale.
- (6) SELECTIVITY)
- (7) AF GAIN) The operating procedure given previously for
- (8) RF and IF GAIN) AM reception is applicable here also.
- (9) AGC; AFC and MUTING)

The information concerning the use of these controls now follows at (C) below.

(C) GENERAL NOTES ON OPERATING PROCEDURE

- (1) AGC : : Automatic Gain Control is of greatest value;
 - a) during general search tuning,
 - b) when monitoring a channel occupied by stations spread over a wide area,
 - c) when receiving a signal that is subject to fading

Actual reception conditions will dictate whether the AGC Switch should be set to AGC SHORT or AGC LONG.

- (2) AUTOMATIC FREQUENCY CONTROL (AFC) : : When the free running local oscillator has been utilized to tune the Receiver satisfactorily to a desired signal, it is of advantage to set the AFC Switch to the ON position. This stabilises the tuning at the operating frequency.

Generally, it is not advisable to employ AFC when receiving a weak signal adjacent to a strong transmission.

- (3) USE OF NARROW BANDWIDTH FILTERS : : Use of the Synchroniser instead of AFC is recommended when employing narrow-band filters.
- (4) MUTING : : If the MUTING Switch is set to the ON position, a carrier-controlled muting circuit is introduced which suppresses noise output in the absence of a signal. This facility is primarily intended for use when the Receiver is employed in a communications role, and as such, leads to considerable reduction in operator fatigue during long listening watches.

A relay incorporated in the Receiver can be used to provide indication of the mute condition (Section 2 "Installation" refers).

A MUTING LEVEL CONTROL is provided at the rear of the Receiver. The control enables the threshold level of noise at which muting occurs to be pre-set. The control should be adjusted as follows:-

- a) With the MUTING Switch in the "OFF" position, and the MUTING LEVEL Control turned fully anti-clockwise, tune the Receiver to the desired signal and adjust all other controls to obtain optimum reception.
- b) Slightly "off-tune" the Receiver to a clear channel adjacent to the signal frequency and set the MUTING switch to the "ON" position.
- c) Advance the MUTING LEVEL Control (clockwise), stopping at the point where noise is suppressed.
- d) Re-tune the Receiver to the required signal frequency and check the normal operation when a carrier is present.

(5) CALIBRATION OF TUNING SCALES : : Precise calibration of the tuning scale can be achieved by following the procedure outlined below:-

- a) Set the controls as follows:-

METER Switch to FM.
RF GAIN Control to maximum.
IF GAIN Control to maximum.
SELECTIVITY Switch to N1.
AF GAIN Control to mid-position.
AGC Switch to MANUAL.

- b) Set the CAL Switch to the 50MHz position. Calibration markers will now be obtained at 50MHz intervals from 450MHz to 1000MHz. When calibrating the tuning scale on the lower frequency range, calibration markers at 10MHz intervals will be obtained by setting the CAL Switch to the 10MHz position.
- c) Set the tuning scale to the nearest scale check point. Now tune to the calibration marker, which will be found in the immediate vicinity of the check point. Adjust the TUNE control carefully to obtain centre-zero indication on the panel meter.
- d) Set the CAL Switch to the "CAL OFF" position.
- e) Maintain the setting of the TUNE Control, and position the scale check point by means of the CAL ADJ Control.

The calibration procedure is now complete.

(D) ANCILLARY EQUIPMENT :

ANCILLARIES : : When operating the Receiver in conjunction with ancillary apparatus; please take note of the following information.

- (1) TELEPHONE HEADSET : : Should be connected to the PHONES socket located on the Receiver front panel, using a standard Jack-Plug. Audio level is determined by the setting of the AF GAIN Control. Optimum results are obtained with/low medium impedance headsets.
- (2) EXTERNAL LOUDSPEAKER : : Audio level is determined by the setting of the AF GAIN Control. The external loudspeaker is automatically muted if a telephone headset is connected to the PHONES Socket.
- (3) 600Ω LINES : : Audio level is governed by the setting of the LINE LEVEL Control located at the rear of the Receiver. The LINE LEVEL Control is completely independant of the AF Gain Control.

NOTE :

The Receiver panel Meter can be utilized to monitor the line audio level, by setting the METER Switch to the "AF" position.

- (4) PANORAMIC DISPLAY UNIT : : Input to the Display Unit will be taken from one of the IF OUTPUT Sockets located on the Receiver rear panel. The output(s) are at 36.5MHz, and when used in conjunction with the Eddystone Model 1061B Panoramic Display Unit, a convertor must be fitted to the Receiver to change the IF output frequency to 21.4MHz.
- (5) In applications utilizing the output derived from the "IF OUTPUT LOW LEVEL" Socket, bandwidth will be governed by the selectivity of the RF tuning circuits.

If the output is taken from the "IF OUTPUT HIGH LEVEL" Socket, bandwidth will be determined by the position of the SELECTIVITY SWITCH.

* NOTE : It is essential to note that when using the receiver with synchroniser, it will take several seconds for frequency stability to be achieved after setting the TUNE/LOCK switch to 'LOCK'.

When operating in the NARROW 2 Mode, it is essential to set the SYNCHRONISER controls to the exact frequency of tune, otherwise the TUNE/LOCK switch will "LOCK" the receiver in an off-tune state. To correct for an off-tune lock state, leave the TUNE/LOCK switch set to the LOCK position. Carefully adjust the SYNCHRONISER controls to obtain "centre deflection" reading on the Synchroniser panel meter.

Section 4

TECHNICAL DATA & CIRCUIT DESCRIPTION

Aerial Inputs

50-75Ω unbalanced.

Output Facilities

Separate 'wide' and 'narrow' IF outputs, positive and negative video, 5MHz standard output, oscillator output ÷ 10, FM audio output, external loudspeaker headset and 600Ω (lines balanced or unbalanced).

Environmental

-10°C to +50°C. (-20°C to +70°C storage).

Calibration Accuracy

Within 1% 440-1000MHz without use of built-in calibrator (Cursor Adjustor at mid-position). Calibrator provides 50MHz markers for precise frequency setting.

Power Supplies

AC	:	100-130V	200-260V (40-60Hz)
AC	:	Consumption	45W (approx).
DC	:	12V with negative earth.	
DC	:	Consumption	36W (approx).

Dimensions & Weight

Rack-mounting Style	:	:	Panel 483mm x 133mm (19" x 5.25")
	:	:	Rack Intrusion 411mm (16.1875")
	:	:	Weight 19.05kg
Bench-mounting Style	:	:	Width 502mm (19.75")
	:	:	Height 164mm (6.5") (Inc. feet)
	:	:	Depth 457mm (18")
	:	:	Weight 24.61kg

Frequency Coverage

Range 1 : : 440 - 800MHz.
Range 2 : : 800 - 1000MHz.

Performance Summary

Typical data : not to be interpreted as a test specification.

Sensitivity (10dB S+N/N with standard output)

MODE	B/W	440-800MHz	800-1000MHz
*AM	400kHz	6 μ V	6 μ V
**FM	400kHz	6 μ V	6 μ V

(*) 30% mod at 1kHz (**) 22.5kHz deviation.

Noise Factor

Typically 10dB.

Image Rejection

440 - 800MHz : : Greater than 40dB
800 - 1000MHz : : Greater than 35dB.

IF Rejection

Greater than 55dB.

Stability

Free-running oscillator : : 1 part in 10⁵/°C.
Synchroniser : : 1 part in 10⁷ *
 (*) -10°C to +50°C.

AFC Capture

At least 1% of signal frequency (operative in free-run mode only).

Selectivity

WIDE	::	4.5MHz at -6dB.	Stopband -45dB.
NI	::	400kHz at -6dB.	Stopband -60dB.

Dynamic Range

35dB (with AGC disabled). Taken for 5% total distortion with 60% modulation at 1kHz.

AGC Characteristics

Less than 10dB change in output for 80dB increase in input from $6\mu\text{V}$.

FM Deviation

Linear acceptance to 75kHz.

Audio Output

Ext. loudspeaker (3Ω) 1.5W at 10% distortion. Line (600Ω with CT) 20mW at 5% distortion
Headset Low-medium-Z. Response within 3dB 200Hz - 8kHz.

Video Outputs

Separate +ve and -ve outputs of 1V p-p into 50Ω .

Video Response

Level within $\pm 3\text{dB}$ 20Hz to 1.5MHz.

IF Outputs (quoted for $15\mu\text{V}$ signal)

Separate wide and narrow-band outputs matched to 50Ω .

Low-level wideband output	:	$15\mu\text{V}$
Narrow-band output *	:	50mV

*Bandwidth set by receiver IF selectivity.

RF Oscillator Output

Greater than 45mV into 50Ω.

5MHz Standard Output

350mV into 50Ω.

FM Audio Output

Approx 900mV into 10kΩ.

Muting

Threshold adjustable down to 6μV carrier.

The above figures are typical only and do not form the basis of a contractual specification.

CIRCUIT DESCRIPTION

This description should be read in conjunction with the circuit diagrams bound at the rear of the Manual.

Introduction

The majority of components in the receiver are housed in sub-assemblies which are classified as modules, units, or boards, according to the nature of their construction. Each sub-assembly has a number. References are allocated to components in each sub-assembly in the conventional manner: R1, R2, C1, C2 etc. To identify a component without ambiguity the number of the sub-assembly in which that component is located is used as a prefix to the component reference e.g. 2R1 refers to resistor No. 1 in No. 2 Unit. 3R1 refers to resistor No. 1 in No. 3 Unit etc. The numerical prefix is not included in the component references on the circuit diagrams or on the printed circuit boards where it is clear to which sub-assembly a particular component belongs.

This system of component identification is extended to include all components in the receiver. Power supply circuit components do not constitute a sub-assembly in the sense described above, but are for convenience grouped together under the classification of No. 15 Unit. Miscellaneous components that are distributed throughout the receiver (e.g. certain front panel controls) are, for identification purposes only, considered to belong to sub-assembly No. 1 and are referenced accordingly. The table which follows, lists all the sub-assemblies that make up the complete receiver.

The circuit description details the function of each sub-assembly, and the relationship to other sub-assemblies and to the receiver as a whole. The associated switches and controls are also described.

SUB-ASSEMBLIES USED IN 1990S RECEIVERS

<u>Reference No.</u>	<u>Description</u>
1	Chassis & Miscellaneous (see text)
2	440 - 800MHz Tuner Unit
3	800 - 1000MHz Tuner Unit
4	Synchroniser Unit
5	Oscillator divide by 10 module
6	Selectivity module
7	FM module
8	AM Detector & Video module
9	AM IF amplifier module
10	Crystal calibrator(s) Unit
11	Synchroniser/AFC amplifier board
12	IF AGC & Muting module
13	24V Switched Mode Board
14	Audio board
15	Power Unit
16	Voltage Invertor Unit
17	Synchroniser invert board

440-800MHz Tuner Unit (Ref. No. 2)

RF Amplifiers:-

A two stage amplifier circuit is employed. The tuning elements consist of half-wave lines with varicap diodes (2D1 to 2D6 : BB105B) at each end. The high frequency limit of the tuning range is determined by the preset potentiometers 2RV1, 2RV2 and 2RV3 which are connected across the tuning voltage line. The low frequency limit of the range is set by trimmers 2C5, 2C11 and 2C14.

When the 440-800MHz range is selected, +10V is applied to the RF amplifier via range switch wafer 1S3. The UHF signal is applied to the base of the 1st RF transistor 2TR1 (BFR90) via a high pass filter having a cut off frequency of approximately 200MHz. Output from 2TR1 is coupled to gate 1 of the 2nd RF transistor 2TR2 (SD303). Gate 2 of 2TR2 is connected to the main RF AGC line.

A bandpass pair of lines is employed between the output from 2TR2 and a coupling loop which transfers the output to a single balanced mixer 2IC1 (5082/9200). The output from the mixer is switched to the IF pre-amplifier and the low level IF output socket via 2D7.

Variable Frequency Oscillator:-

When 440-800MHz range is selected +10V is also applied to the VFO. The oscillator is a Colpitts type, with a tuned line in the collector circuit of 2TR5 (BFR90) and capacity feedback to the emitter from a tap on the line. The low frequency limit is set by trimmer 2C28 and the high frequency limit by pre-set potentiometer 2RV4. 2RV4 is connected across the tuning control voltage line; tuning is by varicap diodes 2D9 and 2D10 (BB105B). Output from the oscillator is amplified by 2TR4 (BFR90) and fed to the mixer 2IC1 (5082/9200) via an emitter follower stage 2TR3 (BFR96).

Oscillator output from 2TR3 is also switched to the divide by 10 Unit (Ref. No. 5) via diode 2D8.

800-1000MHz Tuner Unit (Ref. No. 3)

The circuit configuration is similar to that of the 440-800MHz tuner unit except that a varicap diode is employed at one end of each line only, to allow operation at higher frequencies.

Synchroniser Unit (Ref. No. 4)

Comprehensive information for this Unit is provided in the separate handbook. A brief description of the Unit function is given here, for the purpose of clarification.

The unit contains a constant temperature crystal-controlled oscillator, operating at 5MHz, with an accuracy of ± 1 part in 10^7 . Output from the oscillator is passed to a series of fixed ratio dividers to produce the reference frequency which is applied to one input of a phase detector. The second input to the phase detector is derived from the VFO and the divide by

10 Unit in the receiver, via a series of variable ratio dividers. The front panel control knobs, used to set the variable ratio dividers are calibrated to display the tuned frequency, which is offset from the VFO frequency by 3.65MHz (the receiver 36.5MHz intermediate frequency divided by 10).

When the TUNE/LOCK switch is set to the TUNE position, the variable ratio dividers form part of a frequency counting circuit. This circuit is used to activate either the TUNE HIGHER or TUNE LOWER light-emitting diode, depending on whether the frequency to which the receiver is tuned is below or above the frequency displayed on the Synchroniser dials. If the two frequencies are approximately the same, the LED's flash alternately.

With the TUNE/LOCK switch set to the LOCK position, the output from the phase detector is used to synchronise the VFO with the reference frequency. When the frequency of the VFO is correctly related to the reference frequency, the output from the phase detector is held constant. If the frequency of the VFO drifts, the output from the phase detector changes: a voltage switch of between 0V and -12V is produced: this is applied to the receiver tuning voltage in such a manner that synchronism between the VFO and the reference frequency is maintained. The control signal from the phase detector is also applied to the Synchroniser front panel meter, which is suitably biased so that the centre of the lock range is indicated by the meter pointer at the centre of the scale.

Oscillator Divide By 10 Module (Ref. No. 5)

The module contains a multi-stage wide band amplifier consisting of a dual gate MOSFET input stage 5TR1 (SD308) with automatic gain control, followed by 5TR2 and 5TR3 (BFR90) operating as amplifier and emitter follower stage. The multi-stage wide band amplifier accepts the oscillator output from each tuner unit, via capacitor 5C1. The emitter follower stage (5TR3) is fed into the three-stage integrated circuit wide band amplifier formed by 5IC1 (OM335).

The automatic gain control voltage is rectified by 5D1 (5082-2800) and amplified by 5TR4 (E270) before being applied to the second gate of 5TR1.

The amplifier stage output is fed to the input of the 1200MHz divide by 10 integrated circuit 5IC2 (SP8667B)*. The output derived from 5IC2 is fed to the SYNCHRONISER RF input via socket SK16, and via the buffer stage formed by 5TR5 (BFX89) to the RF OSCILLATOR OUTPUT socket SK17 situated on the Receiver rear panel.

* or SP8666B

Selectivity Module (Ref. No. 6)

The IF Output from each tuner unit is fed via a transformer 6T1 to the first gate of the dual gate MOSFET 6TR1 (SD306). 6TR1 operates as a pre-amplifier tuned to 36.5MHz, with the second gate fed from the RF AGC line. Output from the pre-amplifier is applied to a junction FET 6TR2 (UC734B) operating as an amplifier and switch: then to a 6 section L-C Filter, with a 400kHz bandwidth. The L-C Filter stage is fed to the output via junction FET 6TR3 (UC734B) operating as a source follower and switch. Diode 6D1 (BAX13) also prevents IF breakthrough when other filter positions are in use.

The pre-amplifier also feeds two amplifier stages 6TR4 (BF197) and 6TR5 (BF324) which supply the input voltage to a surface acoustic wave filter (FL1) with a 6dB bandwidth of 5MHz. Output from this filter is amplified by junction FET 6TR6 (UC734B) and fed to the output via junction FET 6TR7 (UC734B) operating as a source follower and switch.

Diode 6D2 (BAX13) is used to prevent IF breakthrough when other filter positions are in use.

A third output from the pre-amplifier feeds the junction FET 6TR8 (UC734B) source follower and switch, providing the extra position for an optional narrow band crystal filter; and then via switching diode 6D3 (BAX13) to a transistor amplifier and switch 6TR9 (BFX89) and thence to the output.

+10V DC is applied at all times to the pre-amplifier stage, but is applied via the SELECTIVITY switch (1S10) only to the stages in use for any particular bandwidth selected.

Extensive supply line filtering is employed to prevent any leakage of signal round the selectivity elements.

FM Module (Ref. No. 7)

The output from the Selectivity Unit is fed to a frequency conversion stage consisting of the balanced mixer 7IC1 (SL641) and a crystal-controlled oscillator 7TR2 (BFX89) operating at a frequency of 57.9MHz. This converts the intermediate frequency from 36.5MHz to 21.4MHz, after which it is passed to an amplifier 7IC2 (CA3028) via the buffer stage 7TR1 (BFX89). After amplification the signal is coupled to the limiting amplifier and FM demodulator formed by 7IC3 (CA3089E).

Audio output from 7IC3 is amplified by 7TR3 (BC107B) and fed to the AM DETECTOR/VIDEO AMPLIFIER MODULE when the FM mode of reception is selected by the AM/FM switch 1S2. 7IC3 also performs three other functions: Firstly, it provides AGC voltage which can be switched to the IF pre-amplifier and RF amplifier when MANUAL GAIN is selected. Secondly, it provides outputs to the Panel Meter for indication of carrier level and accuracy of FM tuning; these outputs are switched by the METER SWITCH. Thirdly, it provides AFC voltage which may be applied to the VFO via the SYNC/AFC amplifier board.

AM Detector/Video Amplifier Module (Ref. No. 8)

Output from the AM IF module is fed to an emitter follower stage 8TR4 (BFX89) and amplifier 8TR5 (2N3866) which is transformer coupled to the diode detector 8D1. The amplifier 8TR5 also feeds the IF OUTPUT HIGH LEVEL socket, via an emitter follower 8TR6 (BFX89) which provides the correct output impedance. Audio output from the AM detector is fed to an audio/video splitter stage 8TR7 (UC734B). Audio signals are routed from the drain of 8TR7 to the audio amplifier board, while signals from the source are fed to the AM video amplifier 8IC2 (CA3020A) via preset level control 8RV2. Audio output from the FM MODULE is fed to a second audio/video splitter stage 8TR3. Audio signals are routed from the drain of 8TR3 to the audio amplifier board, while signals from the source are fed to the FM video amplifier 8IC1 (CA3020A) via preset level control 8RV1. Both video amplifiers deliver signals to the VIDEO OUTPUT/NEG and POS Sockets via relays which operate from the AM/FM switch 1S2. The AM/FM switch also selects AM or FM audio.

Muting control voltage derived from the MUTING/IF AGC MODULE is fed to the base of 8TR1 (BCY71) when the MUTING switch (1S3) is ON. The circuit is so arranged that 8TR3 and 8TR6 are cut off if the noise voltage exceeds a preset level.

A further transistor 8TR2 (UC734B) which is effectively in parallel with 8TR1 energises relay 8RL1 when muting occurs. The relay contacts are routed to the ancillary socket to provide external indication of mute condition if required.

AM IF Amplifier Module (Ref. No. 9)

A second output from the Selectivity unit also feeds three integrated circuits 9IC1 (SL611) 9IC2 (SL610) and 9IC3 (SL610) connected in cascade to provide IF amplification. The output is routed to two circuits; the IF AGC circuit in the MUTING/IF AGC MODULE and the AM detector in the AM DETECTOR/VIDEO MODULE.

Gain control voltage is applied to the first two stages of the Main IF amplifier. Manual control of the gain is provided by the IF GAIN control which forms part of a potential divider chain which is brought into circuit when switch 1S8 is set to the MANUAL position.

Alternatively, Automatic Gain Control may be used, the control voltage being derived from the IF AGC circuit and applied to the IF amplifier when 1S8 is switched to AGC.

Crystal Calibrator Unit (Ref. No. 10)

This unit is controlled by the CALIBRATOR SWITCH (1S4) which has three positions; 50MHz, 10MHz and CAL OFF. Switching to the CAL OFF position, simply interrupts the DC supply which would be connected in either of the other two positions of 1S4. 10IC1 (74S00) is a crystal controlled oscillator operating at 50MHz. When the CAL switch is set to 50MHz, output from the Oscillator is passed by 10C4 to gate 1 of the Mixer 10TR1 (40673). A phase-shift oscillator 10TR2 (BC107B) is utilized to provide modulation at gate 2 of the mixer.

Probes are used to couple the output from the Mixer to the Tuner Units. The output is rich in harmonics which serve as calibration markers throughout the Tuning range of the Receiver.

If the CAL switch is placed in the 10MHz position a decade divider 10IC2 (74H196) wired as a divide by five is introduced by means of 1S4 into circuit between the Oscillator and the Mixer. Calibration markers are then produced in increments of 10MHz.

Synchroniser/AFC Amplifier (Ref. No. 11)

An operational amplifier 11IC1 (741C) is connected to provide a gain of two, to amplify the AFC or synchroniser control voltages.

Muting/IF AGC Module (Ref. No. 12)

Muting: Audio output from the FM MODULE is capacitor coupled to a noise amplifier 12TR1 (BC 107B). A tuned transformer transfers the noise signal at frequencies of 20-23kHz to diodes 12D1 (0A47) and 12D2 (0A47) where the signal is demodulated before passing to an op-

erational amplifier, 12IC1 (741C), connected as a Schmitt Trigger. The output from 12IC1 is the muting control voltage, which is connected to the Audio/Video splitter circuit when the MUTING SWITCH 1S3 is 'ON'. A potentiometer 1RV8 enables the threshold level of noise at which the muting circuit operates to be preset.

IF AGC: The output from the Main IF Amplifier is further amplified by 12IC2 (SL611C) and 12TR2 (BFX89) which is transformer coupled to diode detector 12D3 (5082/2800). An emitter follower 12TR3 (BC107B) is used to transfer the AGC voltage to the Main IF Amplifier via 12D5 (BAX13) and 1S8. The gain of 12TR2 is controlled by potentiometer 12RV1 which is used to preset the AGC voltage level.

24V Switched Mode Board (Ref. No. 13)

An integrated circuit 13IC1 (TL497) is used as a switched mode inverter circuit to step up the receiver +12V supply to +24V DC for use with 5IC1 in the OSCILLATOR DIVIDE BY 10 MODULE. The inverter operates at a frequency in the region 80-100kHz. 13RV1 is used to adjust the output voltage to exactly +24V.

Audio Amplifier Board (Ref. No. 14)

Audio signals from the Audio/Video splitters enter the Main Audio Amplifier stage via AF GAIN control potentiometer 1RV2. The amplifier employs an integrated circuit 14IC1 (TBA810). Output is taken to the PHONES jack with 1R3 in series for impedance matching.

External loudspeaker connections are also made via the PHONES jack so that the external loudspeaker is automatically disconnected if telephones are used. Output is also taken to the internal loudspeaker connected in series with LS switch 1S5 and 1R2 which is in circuit to limit the output power to an acceptable level.

Line Amplifier: Input to this amplifier is obtained from the Audio/Video splitters via the pre-set LINE LEVEL potentiometer 1RV3. A source follower stage 14TR1 (UC734B) feeds an integrated circuit amplifier 14IC2 (TCA760), the output of which is taken via a transformer to match 600Ω lines. A centre tap on the transformer secondary is provided to enable a balanced output to be obtained.

In addition, a rectified output derived from 14D2 (0A47) is connected to the Panel Meter when the METER switch 1S6 is in the 'AM' position; the meter then gives an indication of line audio level. 14RV1 is used to set the meter initially to zero.

Power Supply (Ref. No. 15)

Taking its input from any standard 40-60Hz AC mains supply, this circuit utilizes a toroidal wound step-down transformer and a bridge rectifier 15D1 (BYW21). A voltage regulator 15IC1 (78H12) provides a nominal +12V regulated supply.

A separate voltage regulator 15IC2 (7805KC) fed from the +12V supply provides a +5V DC supply. The +12V supply also feeds three zener diodes (15D3, 15D4 and 15D5 (BZY93 C10)) to provide +10V supplies.

When the BATTERY/MAINS switch 151 (mounted on the front panel) is set to BATT, the mains supply transformer and rectifier are disconnected, the +12V regulator is also switched out of circuit, the +12V supply being taken directly from the battery. Reverse polarity protection is provided by 15D2 which takes sufficient current to rupture the d.c. fuse 15F3.

Voltage Invertor Unit (Ref. No. 16)

This Unit is specifically designed to provide DC supplies of -18V and +33V (fully floating) when the Receiver is operated from a 12V battery.

However, it is convenient to continue to derive these supplies from the Unit when the Receiver is operated from AC mains.

A square-wave oscillator is used, the output from which is stepped up, rectified and voltage regulated. The oscillator circuit is formed around 16TR1 (BDX36) and 16TR2 (BDX36) working in conjunction with transformer 16T1. Output is taken from two secondary windings on 16T1 to the bridge rectifiers 16D3 - 16D10. A supply of -18V is obtained from the voltage regulator circuit 16IC1 (UA723) together with 16TR3 (2N4918), the exact voltage level being preset by 16RV3. A similar circuit is used to provide the +33V supply.

Synchroniser Invert Board (Ref. No. 17)

This circuit stage takes a negative going control voltage from the synchroniser unit and inverts it to provide a positive going voltage. The positive going voltage is fed to the VFO control line when the SYNC/AFC SWITCH (157) is set to 'SYNC'. The voltage inversion stage is formed by 17TR1 (BC107B). A potentiometer 17RV9 mounted on the receiver side plate sets the DC level to coincide with that of the AFC voltage generated in the FM MODULE.

Section 5

MAINTENANCE

General

The receiver is suitable for continuous use under arduous conditions and normally requires no routine maintenance, apart from occasional lamp replacement. This section describes the procedure for fault diagnosis and the replacement of component modules and assemblies. The location of these are shown in Figures 5-1 and 5-2.

Instructions are also included for Performance Testing and Realignment.

NOTE:

When working on the receiver it will be necessary for power to be connected. It is recommended that the receiver is fed from an isolated power supply and that normal precautions for safety under these conditions be observed!

Fuse Replacement

Double-pole fusing is employed in the AC Mains supply and single pole fusing in the positive side of the 12V DC supply. The two AC fuses are 'time-lag' type, 20mm x 5mm glass cartridge; and the DC fuse is the 'quick blow' type with similar dimensions. All fuseholders are located on the rear panel.

The fuse ratings are:

12V DC	5 AMP	
210-260 AC	0.5 AMP	Time-lag
110-130 AC	1 AMP	Time-lag

Spare fuses are supplied in the Accessories Kit (See page 2-8).

Tuning Scale Lamp Replacement

In the event of one (or both) of the tuning scale lamps failing, the procedure for replacement is as follows:-

1. Remove the receiver from the cabinet, or rack, and remove the top dust cover.
2. Remove the two screws securing the lamp mounting board and lift the board to the limit of the slack in the wiring.
3. The soldered connections to the faulty lamp will now be accessible. Desolder the faulty lamp and fit the replacement (a spare lamp is included in the Accessories Kit).
4. Replace the lamp mounting board and screws, and refit the dust cover. Replace the receiver in the cabinet or rack and check that both lamps now light, and that the Receiver functions correctly.

Range Indicating Lamp Replacement

It is unlikely that these lamps (LED's) will fail; however should a failure occur, the procedure is as follows:-

1. Remove the receiver from the rack or cabinet and remove the top dust cover.
2. Remove the CAL ADJ knob. This is done by removing the cap and holding the knob stationary while turning the screw anti-clockwise to release the collet.
3. Remove the four crosshead screws at each corner of the tuning scale escutcheon and remove the complete assembly; i.e. the outer escutcheon, the window and the inner escutcheon.
4. Remove the Synchroniser Unit by removing the four screws securing the Unit to the Receiver front panel.
5. Remove the two screws, nuts, and washers, holding the LED mounting board.
6. Lift the LED mounting board upwards to the limit of the slack in the wiring.
7. The faulty LED is now accessible and may be desoldered.
8. Take the replacement LED and note the cathode lead. Bend the leads to match those of the original LED and solder the replacement in position with the cathode lead nearest the top of the board.
9. Refit the board, escutcheon assembly, knob, synchroniser, and cover, by reversing the above procedure.

Removal of Modules

The modules covered by this procedure are:-

FM, Main IF Amplifier, AM Detector/Video, Muting/IF AGC, Selectivity.

1. Remove both top and bottom dust covers.
2. Remove any co-axial connectors from the top of the module. Note position of connectors prior to removal.
3. Using the tool provided, release the cover retaining clip or clips, and remove the cover from the module in question. Disconnect any leads to the interior of the module. (NOTE: FM Module cover is retained by screws).
4. Stand the receiver on its side and disconnect the leads at the base of the module.
5. Remove the two screws (with earth tags) securing the module, and remove the module.

N.B. Before disconnecting any leads ensure that they are identifiable to allow correct replacement; also that all earth tags are replaced and make good connection.

In certain modules, the leads terminate in soldered joints; these leads should be disconnected where they enter other modules. Also in some cases leads are brought up at the wiring side of the printed circuit boards and should be replaced in the same positions.

Removal of Voltage Invertor Unit

1. Remove both dust covers and stand the receiver on its side.
2. Disconnect the 6 way plug on the underside of the chassis.
3. Support the weight of the unit and remove the four screws on the underside of the

chassis, securing the unit. Two of the securing screws are located adjacent to the connector, the remaining two are beneath the wiring between the 15 way socket and the zener diodes. The unit is now free to be removed.

4. Replace the unit by reversing the procedure, taking care not to trap any leads on the top of the chassis with the body of the unit.

Removal of Audio Amplifier Board

1. Remove the cover on the outside of the left-hand side plate by removing the centre screw at each end.
2. Disconnect the leads and remove four screws from the plastic pillars at each corner of board.
3. Remove board. Replacement is by reversal of above procedures.

Removal of Synchroniser Invert Board

1. Remove the Synchroniser by removing the four screws at the corner of its front panel.
2. Remove the top cover situated over the synchroniser aperture (six screws).
3. Remove the four screws, nuts, and washers, securing the potentiometer mounting board in the right hand side plate and allow the assembly to hang free.
4. Remove the four crosshead screws which secure the plate carrying the Sync Invert board, the 8 way socket, and the co-axial socket assembly, to the rear panel (behind the synchroniser position). This assembly may now be lifted upwards to the limit of the slack in the wiring to allow access to the securing nuts on the underside.
5. Disconnect the leads to the Sync Invert board and remove the two screws, nuts, washers, and spacers, securing the board to the assembly.
6. Replace the board by reversing the above procedure. When replacing the assembly on the back panel, ensure that the rubber grommet which protects the cables entering the underside of the assembly, is correctly located. Note that the free movement of the BNC sockets is intentional.

Removal of Tuner Units

440-800MHz :

1. Remove four screws securing the tuner box to the chassis plate (two are located between the miniature coax sockets at each end of the Divide by 10 Unit and accessible from the top of the receiver and two are reached from the bottom of the receiver and are located at the corners of the RF unit).
2. Disconnect the co-axial plug on the lead from the RF unit to the Divide by 10 Unit, and disconnect the in line co-axial connector from the tuner to the Selectivity Unit.
3. Lift the unit to the limit of the wiring and remove the cover (four screws and two hexagon head screws): the hexagon screws need not be removed, as the cover is slotted.
4. Remove the four screws securing the printed circuit board to the box and carefully slide the box free from the board.
5. The leads should now be detached from the circuit board, which can then be removed from the receiver.
6. Replacement is a reversal of the above procedure.

800-1000MHz :

1. Remove the RF tuner unit cover (four screws and two hexagon screws; the hexagon screws need not be removed completely as the cover is slotted). Remove the four screws securing the tuner unit to the chassis plate (two are located at each end of the tuner and are accessible from the top of the receiver. The other two are accessible from the bottom of the receiver and are located at the side of the chassis plate).
2. Remove the IF output lead (which is routed through a grommet in the side of the box) by unsoldering.
3. Remove the four screws holding the printed circuit board in the box, and carefully draw the box away from the board.
4. The leads should now be detached from the printed circuit board, which can then be removed from the receiver.
5. Replacement is a reversal of the above procedure.

NOTE: When removing the RF units, great care must be taken to note the exact position of all leads before removal, to facilitate correct replacement.

Removal of Oscillator Divide by 10 Unit

To remove the Divide by 10 Unit it is first necessary to remove the 440MHz-800MHz Tuner Unit from the RF chassis. By detaching the IF lead and oscillator output lead, and removing the four screws holding the RF Unit to the chassis, it will be possible to lift the box sufficiently to gain access to the two screws securing the Divide by 10 Unit. Taking careful note of their position, remove the four co-axial connectors and the +10V and +24V supply leads from the feedthrough capacitors; the Divide by 10 Unit may now be removed from the receiver. Replacement is a reversal of the above procedure. NOTE! Take extreme care when replacing the +10V and +24V supply leads, as reversal of these may cause damage to the unit.

Removal of Crystal Calibrator Unit

1. Remove the two screws holding the Calibrator Unit mounting bracket to the Drive Assembly.
2. Disconnect the leads and lift both the Unit and mounting bracket clear of the Receiver.
3. Remove the bracket from the unit.
4. Keep the screws that secure the calibrator unit separately, as these are imperial (not metric as for the other units).

Removal of Front Panel

1. Withdraw the Synchroniser Unit, after first removing the four screws in the front panel.
2. Position the receiver so that the front panel just overhangs the front of the workbench.
3. Remove the control knobs. This is done by removing the cap to reveal the collet, and holding the knob stationary while turning the nut anti-clockwise, using the box spanner supplied in the Accessories Kit. The smaller knobs may use a screw in place of a nut; the method is however the same.

4. Remove the nuts and washers securing the toggle switches and Phones jack in position. Ensure that the switches do not push-back to damage the tuning scale.
5. Remove the screws, nuts, and washers, securing the loudspeaker and meter.
6. Remove the four large screws securing the handles and the ends of the panel (noting the "make-up" of the spacers at the left-hand end).
7. Slacken the nuts on the two remaining large screws and unscrew these from the centre support plate, supporting the panel as it finally becomes free.
8. To replace the panel reverse the procedure.

NOTE: The spacing of the nuts on the centre support plate can be derived from the spacers removed from the left-hand end of the panel.

The switches should be located as the panel is offered up into position, and care should be taken to ensure that they are not "pushed-back" to damage the tuning scale.

Removal of Tuner Unit Chassis and Drive Assembly

1. Stand the receiver on its side, having first removed the dust covers.
2. Unsolder the flexible earthing to the rear of the Tuner Unit chassis.
3. Remove the large retaining screw, nut, and rubber washers, at the rear of the Tuner Unit chassis.
4. Remove the Crystal Calibrator Unit and the Front Panel, as described previously. Disconnect the 15 way plug at the rear of the Tuner Unit, and disconnect the miniature co-axial plugs from the Divide by 10 Unit.
5. Unscrew, and detach from the rear panel, Aerial input 1, Aerial input 2, and IF Output Low level BNC co-axial sockets. Mark each socket to ensure correct replacement.
6. Disconnect the nuts securing the RF/IF Gain, Fine Tune, Selectivity switch and Audio Gain controls to the front sub-panel (which is part of the Drive Assembly).
7. Remove the four smaller hexagon screws located near the corners of the sub-panel.
8. The Tuner Unit and Drive Assembly may now be pulled forwards (allowing the switch and potentiometers to fall clear) and completely removed. The Drive and Tuner unit assembly should be stood on its side to avoid damage to the tuning potentiometer and gearing.
9. Replace the assembly by reversing the above procedure.

Replacement of Tuning Scale

1. Remove the Front Panel as described.
2. Remove the two countersunk screws securing the Scale Lamp Board and the Masking Plate.
3. The Scale Lamp Board and Masking Plate may now be tilted upwards, and over, towards the back of the receiver to the limit allowed by the wiring. A fibre washer is located on the pin situated on the radial arm, between the face of the arm and the cursor: ensure that this washer is not mislaid. Slide the cursor sideways out of the guides, noting that the slot is vertical and at the top left-hand corner.
4. Remove the two countersunk screws in each Cursor Guide and Pressure Pad Assembly and remove these completely.
5. The scale is now ready to be removed. It is retained on the take-up spools by its own tendency to curl and it is simply pulled off tangentially.

6. The new scale can now be fitted. When doing so take great care to ensure that it is not scratched or otherwise damaged. Identify the left-hand end of the scale and feed this onto the left-hand spool, allowing the scale to curl around the spool.
7. Continue feeding the scale onto the left-hand spool until the "0" mark on the logging scale is produced.
8. Unwind the remainder of the scale and feed the right-hand end onto the right-end spool. (It may be advisable to practice this with the discarded scale if possible). Set the "0" mark on the logging scale as near central as possible on the sprocket drum and locate the perforations on the sprocket teeth.
9. Replace the Cursor Guide and Pressure Pad assemblies and screws.
10. Tune the receiver over the full length of the scale and check that the scale runs freely. A very slight smear of petroleum jelly on the sprocket teeth may be beneficial. Clean the Cursor with perspex cleaner incorporating an anti-static agent, and replace, ensuring the slot is in the correct position. The Cursor should be free to move sideways but with enough friction to prevent movement by vibration or accident.
11. Replace the Masking Plate. Ensure the pin on the radial arm enters the slot in the cursor and that the fibre washer is located correctly between the arm and the cursor. Replace the Scale Lamp Board and screws which will then hold the Masking Plate, and re-check the cursor measurement. Tune the receiver fully anti-clockwise and check that the reference mark on the masking plate, the cursor and "0" on the logging scale, all line up. If they do not, the scale position may be adjusted. Remove the two screws on the take-up spool brackets and carefully move the Crystal Calibrator Unit backwards a short distance. It will then be possible to gain access to the two grub screws securing the sprocket drum. These should be slackened and the scale re-positioned.
12. Ensure both drums are tight against the bearing faces (i.e. towards each other) and re-tighten both grubscrews.
13. Replace and secure the Crystal Calibrator.
14. Replace the front panel.

Fault Diagnosis

The purpose of this section is to provide a convenient guide to a procedure which will lead to the most rapid identification of a fault area. The procedures are not the only method; and do not attempt to define every fault. Where it is obvious that a fault lies in one particular module, then systematic investigation of that module is advised. The performance of any module should be compared with the figures given in the "Performance Testing" and "Realignment" sections, making due allowance for normal tolerances. Most of the transistor and integrated circuit terminal voltages are given in the voltage analysis tables.

1. Check that the receiver is powered and all external connections are correct; also that no fuses have blown and that all controls are set correctly.
2. Switch off 'MUTING', AFC; set AGC to manual; advance to about 75% rotation RF GAIN, IF GAIN, AF GAIN and LINE LEVEL; switch on LS.
3. Establish whether lack of reception occurs on both ranges and/or in both modes and/or in all bandwidths.

Table 5-1 should then be consulted.

TABLE 5.1. FAULT LOCATION GUIDE

FAULT SYMPTOM : NO RECEPTION ON ALL RANGES AND IN ALL POSITIONS OF MODE AND SELECTIVITY.

POWER SUPPLIES

Check availability of main supply voltages:-

+12V at 15C2
 +10V at cathode of 15D3
 +10V at cathode of 15D4
 +10V at cathode of 15D5
 + 5V at 15C4

If voltages are normal check modules, etc. in the following order:-

AUDIO AMPLIFIER BOARD

Check that +12V supply is present at Pin 84; if absent test for continuity back to power unit. Check that all connections to the module are secure.

There are two separate audio channels and it is most unlikely that both will fail simultaneously. Therefore, if no output can be obtained on both channels and the supply voltage is satisfactory it is probable that the Audio Amplifier Board is operational and the fault lies elsewhere in the receiver.

If only one audio channel is dead check the input and output leads and the appropriate gain control before carrying out a detailed examination of the circuit.

AM DETECTOR AND VIDEO AMPLIFIER UNIT

Check that +12V supply is present on Pin 1 and Pin 13.

Check all connections to the module; particularly check the output of the audio/video splitter stage for a short circuit as this will affect both audio amplifiers. Short pin 19 to pin 21 to bypass the splitter stage, in FM Mode only. If signal output can then be obtained on the main audio channel the audio/video splitter stage should be thoroughly checked.

If no audio output is obtained when pin 19 is connected to pin 21 the module is probably operational but there is no signal input. Examine the screened input lead to pin 19 for open circuit or short circuit. Also check contacts on AM/FM switch 152.

Separate splitter stages are used for AM and FM modes and it is unlikely that both will fail simultaneously, so before making the above tests check whether output is obtained in either mode.

SELECTIVITY UNIT

Check that +10V supply is present at pin 4 and pin 1 (with selectivity switch set to N1) and at pin 4 and pin 2 with selectivity switch set to 'WIDE'. If this voltage is absent check continuity back to power unit via selectivity switch 1S10.

It is unlikely that 'WIDE' and 'N1' selectivity circuits will fail simultaneously. Therefore, if the supply voltages are normal but reception cannot be obtained in both positions of the Selectivity switch, the IF Pre-amplifier should be checked since it provides a common output to the filter circuits.

Ensure that +10V supply is present at pin 4. Inject a modulated 36.5MHz signal at a level of 3 μ V. This signal is conveniently introduced at the in line co-axial connector at the input to the unit.

TUNER UNITS 440-800MHz and 800-1000MHz.

Ensure that +10V supply is present on the tuner unit. If voltage absent, check continuity back to power unit via range switch 1S9.

Check security of all connections to the unit.

It is unlikely that both units will fail simultaneously. Therefore, if there is no reception on both ranges and the supply voltages are normal, the fault is probably external to the unit. Lack of -33V supply to the tuning potentiometer will inhibit tuning on both ranges.

If signals cannot be received on only one range, examine the appropriate output leads for open circuit and short circuit. Do not overlook the diode in the IF output feed from the tuner.

FAULT SYMPTOM : NO RECEPTION ON ANY RANGE IN FM MODE ONLY

FM MODULE

Ensure that +10V supply is present at pin 1 and check that other connections to the module are secure. Examine screened lead from pin 7 for open circuit or short circuit. Check the AM/FM switch 1S2. Check the FM module thoroughly.

FAULT SYMPTOM : NO RECEPTION IN AM MODE;
FM MODE NORMAL

AM IF AMPLIFIER MODULE

Ensure that +10V supply is present at pin 32 and check that other connections to the module are secure.

Examine the co-axial lead to socket on side of module for open or short circuit. Also check for short circuit on the two co-axial output leads. Check AM/FM switch 1S2.

AM DETECTOR AND VIDEO AMPLIFIER

Ensure that +12V supply is present on pins 1 and 13. Examine co-axial input lead for open circuit.

Check the module. The IF OUTPUT HIGH LEVEL should be approx. 50mV into 50Ω for 15μV input at the aerial socket. If this output is obtainable the fault lies in the AM Detector stage.

PERFORMANCE TESTING

Overall Performance

If substandard performance is suspected, the receiver should be withdrawn from service and subjected initially to the overall performance checks detailed below. The use of the test equipment listed is recommended, but other equipment with equivalent specification and performance can be used. The internal meter can be used for many of these checks, provided the line output (Ancillary socket pins 9 and 11) is terminated in 600Ω.

RF Signal Generator 450kHz - 1100MHz AM/FM/CW. 0.1μV - 2V
output 50Ω impedance. Hewlett-Packard 8460B.

Audio Signal Generator 20Hz - 20kHz.
Marconi TF 2000.

Output Meter 1mW - 10W, load 3Ω minimum.
Marconi TF 893A.

High Impedance Voltmeter. Max. sensitivity 1mV frequency range
10Hz - 1000MHz. Marconi TF 2603.

Multimeter 20KΩ/V AVO8.

Frequency Counter Max. frequency 1100MHz.
Racal 9025.

For visual alignment a Marconi Spectrum Amplifier TF 2370 is recommended.

Overall Sensitivity

Set the controls as follows:

RF Gain	:	MAX	Supply	:	as required
IF Gain	:	MAX	Muting	:	OFF
Fine Tune	:	CENTRE	AGC	:	OFF
Selectivity	:	N1	AFC	:	SYNC (AFC OFF)
Mode	:	AM	Cal	:	OFF
AF Gain	:	As required	Tune/Lock	:	TUNE
LS	:	ON	Range	:	1
Meter	:	AF			

Set the signal generator to 470MHz 30% Amplitude Modulation at 1kHz and connect to AERIAL INPUT 1.

Connect the AF Power Meter to Pins 1 & 2 on ancillaries socket and match to 3Ω impedance. Tune the receiver to 470MHz and check that a Signal/Noise ratio of 10dB is obtained for an RF input of less than 6μV.

Repeat this for a frequency near the centre of the range and a frequency of 770MHz.

Connect the Signal Generator to AERIAL INPUT 2 and set at a frequency of 830MHz. Switch the receiver to RANGE 2 and tune to 830MHz. Check that the signal/noise is 10dB for an RF input of less than $6\mu\text{V}$.

Repeat this for a frequency near the centre of the range and a frequency of 970MHz.

Repeat all the above procedures with the MODE switch set to FM and the signal generator frequency modulated with 22.5kHz deviation at 1kHz. A signal/noise ratio of 10dB should be obtained with an RF input of less than $6\mu\text{V}$.

If all sensitivities are consistently low then it is likely that the fault lies in the IF pre-amplifier, Filter, Audio/Video unit or Audio Output stages.

Transfer the Power Meter with impedance changed to 600Ω to the 600Ω output (ancillaries socket pins 9 and 11) to determine whether this is also low, (but beware of double terminating this output). It should agree with the internal meter at the 10mW level.

Check also the video outputs - nominal output is 1V p-p into 75Ω (or 1.6mW into 75Ω). If all are consistently low, then the fault is likely to be in the IF stages.

IF Sensitivity

Set the signal generator to 36.5MHz 30% Amplitude Modulation at 1kHz. Disconnect the in-line co-axial connector between the Tuner Units and the Filter Module and connect the signal generator to the Filter Input.

With the AF gain control set to maximum and SELECTIVITY TO N1 the output should be 100mW for $1-2\mu\text{V}$ pd input. Check that a signal/noise ratio of 10dB is obtained with an input of less than $3\mu\text{V}$ pd. This will reveal if the IF sensitivity is low. Reconnect the in-line co-axial plug and socket.

Image Rejection

Set the signal generator to $6\mu\text{V}$ output 30% AM at 1kHz and connect to AERIAL INPUT 1. Tune the receiver to a convenient frequency near the centre of the tuning range and set the AF gain to give an output of 50mW on an output meter.

Now tune the signal generator to a frequency 73MHz above the frequency previously selected. Increase the output of the signal generator until 50mW is obtained on the output meter and note the increase in dB. A figure greater than 40dB should be obtained.

Repeat the above procedure on Range 2 with the generator connected to AERIAL INPUT 2. A figure greater than 30dB should be obtained on this range.

IF Rejection

Set the signal generator to $6\mu\text{V}$ output and tune to a frequency at the centre of each range setting, an output meter reading of 50mW should be obtained. Return the signal generator to 36.5MHz and note the increase in output needed to obtain 50mW output meter reading. A figure greater than 55dB should be obtained on Ranges 1 and 2.

AFC Capture

Set AFC to off. Synchroniser to TUNE and Muting OFF. With the signal generator set to $20\mu\text{V}$ output at 650MHz tune in the receiver. Adjust the receiver frequency by 0.5% either side of centre frequency and check that when AFC is switched on the receiver pulls into tune. Recheck at 900MHz on Range 2.

Selectivity

Disconnect the in-line co-axial connector between the tuner units and the Selectivity Unit Module and connect the signal generator to this. Set the signal generator to $10\mu\text{V}$ output at 36.5MHz (30% AM at 1kHz). Set selectivity and adjust AF gain for 50mW output on meter. Increase the signal generator by 6dB and return the generator each side of centre to obtain the original 50mW output, -6dB points at $36.5\text{MHz} \pm 200\text{kHz}$.

Repeat the above with generator output increased 60dB .

-60dB points + 1.5 to 3MHz - 2.5 to 3.5MHz .

Repeat above procedure with selectivity set to WIDE.

- 6dB points 4 to 5MHz .

-50dB points - 4.5 to 6MHz + 5 to 6.5MHz .

Reconnect tuner lead.

AGC Action (AGC on)

Connect the signal generator to INPUT 1. With the generator and receiver set to 770MHz and generator output $6\mu\text{V}$, check that the output of the receiver changes by less than 10dB for a change of 80dB in input level. Recheck at 970MHz on Range 2.

IF Outputs

With the signal generator set to $15\mu\text{V}$ at any convenient frequency check that IF outputs are as follows:-

Low level $15\mu\text{V}$ into 50Ω (wide bandwidth)

High level output 50mV into 50Ω (bandwidth set by selectivity control).

Muting Action

Connect the signal generator to AERIAL INPUT 1 and set at 770MHz (30% AM at 1kHz). Set MUTING to ON and MUTING PRESET to maximum. The muting should lift for an input of greater than $6\mu\text{V}$.

Frequency Accuracy

Set CAL ADJ control to central position, set internal crystal calibrator to 50MHz and check that a harmonic of the crystal oscillator appears every 50MHz over the entire range with an accuracy of $\pm 1\%$. It may be convenient to use 10MHz facility on the lower range. Spurious responses from the crystal should be at least 20dB below the wanted harmonics.

NOTE : : 10MHz harmonics will not be obtained at all frequencies on Range 2.

Re-alignment

General

All modules and units employed in the receiver are pre-aligned on factory test jigs before they are fitted to the main chassis assembly, and further adjustment to the module circuits is not normally required.

Replacement Modules or Units supplied for user servicing are also pre-aligned in this way and can be installed without the need for major adjustment. Instructions for carrying out any minor adjustments which may be required in some cases due to design or other changes will be furnished with the replacement item.

Re-alignment should be carried out only by skilled technicians having a sound knowledge of the procedures and the special techniques involved, particularly where adjustments to the UHF tuners may be contemplated. If there is any doubt as to the ability to carry out the complete re-alignment, then the receiver may be returned to the manufacturer for attention, full details are given in the introduction to this manual. When dealing with the modules where high frequency operation is involved, it will be necessary to manufacture locally dummy cover lids which have the necessary holes cut to allow access to the adjustment points. The original cover lids may be used as templates for this. After making the adjustments re-fit the original lid and ensure that the adjustment is still correct. A very slight re-adjustment may in some cases be required. All preset adjustments - trimmers, cores etc. - are self locking and need not be sealed with wax or similar compounds.

Power Supply and Voltage Invertor Unit

Warning: Disconnect completely from supply and allow all electrolytic capacitors to discharge completely.

Check the supply rails for short circuits, the resistance to earth (negative of meter to earth) should be approximately 9Ω for the +12V, 15Ω for the +10V (measure across 1D3), 12.5Ω for the +10V supply (measure across 1D4), 11.5Ω for the +10V supply (measure across 1D5), 9Ω for the +5V supply. 800Ω for the -18V supply and $16k\Omega$, and $10k\Omega$ for the +33V positive and zero lines respectively to the UHF tuners.

Check the resistance from mains input line and neutral to earth, this should be greater than $20M\Omega$.

Now connect the mains to the receiver and switch on:

Check the +12V line (red leads on terminations adjacent to electrolytic capacitors) lies between the limits 11.4V to 12.6V.

Check the three +10V lines (measure across the three zener diodes on power unit chassis) lie between the limits 9.5V to 10.5V.

Check the +5V line (measure across capacitor 1C4) is within the limit +4.75V to 5.25V.

Check the -18V line (measure on pin 5 of six pin connector) and adjust to exactly -18V with 16RV3 (inside inverter unit).

Check the 33V supply (screened lead on pins 3 and 4 of six pin connector) and adjust if necessary by means of 16RV4 (inside inverter unit) to obtain exactly 33V.

NOTE: THIS SUPPLY IS FLOATING WITH RESPECT TO GROUND.

Initially set the controls as follows:

RF Gain	::	MAX	MUTING	::	OFF
IF Gain	::	MAX	AGC	::	MANUAL
AM/FM	::	AM	WAVEBAND	::	RANGE 1
Selectivity	::	N1	SYNCHRONISER	::	TUNE
AF Gain	::	MID position	SYNC/AFC	::	SYNC

IF Stages

Connect an output power meter matched to 3Ω to pins 1 and 2 of ancillary socket. Disconnect tuner output from selectivity input lead (in line co-axial connector). Set the signal generator to 36.5MHz amplitude modulated 30% at 1kHz and connect to selectivity input lead. Adjust AF gain to maximum and set the signal generator to obtain an output of 100mW (the generator level should be approx $2\mu V$). Repeat with the selectivity control set to WIDE. The output should be within +4dB of that obtained in N1. Slowly decrease the IF gain and check that the output falls in sympathy with this. Any instability will be revealed by the output rising and then falling away more rapidly. If instability is present check all connections to the IF amplifier and selectivity modules paying particular attention to the earth connections.

Set the signal generator output to obtain a 10dB signal/noise ratio, it should be approximately $2.5\mu V$ for N1 selectivity position.

Selectivity Unit

NOTE: For optimum results a Spectrum Analyser should be used. However, the following method can be used in cases of emergency.

Set AM/FM switch to AM and selectivity to N1.

- a) Set the signal generator to 36.5MHz with 30% AM at 1kHz to give a receiver output of 100mW. Tune cores of L1, L2, L5, and L8 for maximum output, reducing the generator voltage as necessary.
- b) Set the signal generator to 32.3MHz, increase output to give a receiver output of 50mW and tune L6 for minimum, increasing generator voltage as necessary.
- c) Set generator to 33.6MHz and adjust output to give receiver output of 50mW and tune L7 for minimum, adjusting generator level as necessary.
- d) Set generator to 40.1MHz, adjust output to give receiver output of 50mW and tune L3 for minimum, adjusting generator level as necessary.
- e) Set generator to 40.8MHz, adjust output to give receiver output of 50mW and tune L2 for minimum, adjusting generator level as necessary.

Repeat operations a) - e) until no further improvement is possible.

Turn SELECTIVITY to 'WIDE' and check that output does not vary by more than ± 3 dB from that obtained in N1.

Check that selectivity is within the limits below:

	-6dB	-50dB	-60dB
WIDE	4.1 - 5.5MHz	9 - 12MHz	-
N1	350 - 450 kHz	-	4 - 7MHz

AM Detector and Video Amplifiers

AM Detector:

Adjust signal generator for 60% amplitude modulation and adjust output to obtain 10mV measured at the input to the AM detector (Pin 14) using a high impedance RF millivoltmeter.

Adjust C21 for maximum output from the receiver. Increase the signal generator output to 100mV p.d; the audio output measured across test point ("T.P." and Earth) should be 1 to 1.5V RMS, and the IF Output High Level on pin 22 should be 0.45 to 1.25V RMS.

Audio Video Splitter and Video Amplifiers

Connect Audio Generator to PCB Test Point terminal designated "T.P." Set Mode switch to AM. Set generator to 1kHz with 50mV RMS output. Adjust RV2 to give 1V p.p. on each video output (pins 6 and 3). Check that the response is less than -3dB at 20Hz. Connect signal generator (set to the same reference level as the audio generator) and check that response is within -3dB to 6MHz.

Reconnect the audio generator and check the audio output on pin 16 and E is in the range 90-120mV p.p. and that the relative response is less than 6dB down at 20Hz and 14kHz.

Connect Audio Generator to pin 19, set Mode switch to FM and repeat above adjusting 8RV2 for video outputs. Check audio output on pin 21 and E.

FM Module

Set AM/FM switch to FM. Tune signal generator to 36.5MHz (modulation off) and connect to input co-axial connector SK14.

Connect a frequency counter to 7R2 and earth, and check that XL1 is oscillating at 57.900kHz \pm 1kHz. Connect an RF millivoltmeter to the same point and check that the voltage is 100-130mV RMS. Connect an RF millivoltmeter to the test point set to 10mV range. Start with all cores near the top of the former and adjust L1, L2 and L3 for maximum output reducing signal generator output as necessary. Set the signal generator for 20mV at the test point and check that the -3dB points are within the limits 36.25MHz to 36.35MHz and 36.65MHz to 36.75MHz. Set the generator to 36.5MHz and transfer meter to terminals 11 (+) and 4 (-) (set meter to 1.5mA centre zero). Adjust 7L5 for zero current, increasing meter sensitivity as necessary. Check that the discriminator curve lies within the limits below:

36.2MHz	16-22.5 μ A
36.3MHz	10.5-14.5 μ A
36.4MHz	5.5-6.5 μ A
36.5MHz	0
36.6MHz	5.5-6.5 μ A
36.7MHz	11.5-15.5 μ A
36.8MHz	19-25 μ A

Muting & IF AGC Module

Check voltage across D3 is +6V \pm 10%. Set signal generator to 36.5MHz (modulation off). Disconnect co-axial lead on termination and connect generator with output level of 10mV. Adjust RV1 fully anti-clockwise from the top of the board. Connect a 2.2k Ω resistor across terminations 40 and 42 also connect a DC voltmeter (10V range) in parallel. Set AGC switch to 'MANUAL'.

Tune trimmer C17 for maximum keeping voltmeter reading below +4V by adjusting generator output and check that maximum voltage obtainable on voltmeter is +5.3V to +5.9V.

Reduce generator output and check that for a voltmeter reading of +5V, generator output is 1.5 to 3mV. Reduce generator output until voltmeter indicates +2V and check that generator output has been reduced by 5 to 7dB relative to the reading for +5V output. Set generator output to 2.5mV and adjust RV1 for +3V on voltmeter. Reconnect input lead.

Muting Section

Switch MUTING to 'OFF'.

Connect Audio Generator to terminations 6 and 7 (earth).

Set MUTING LEVEL to give +3V at termination 3 and earth.

Set Audio Generator to 23kHz.

Connect DC voltmeter to termination 4 and earth.

Connect the RF millivoltmeter to termination "T.P." and earth.

Tune core of T1 for maximum reading at "T.P."

Check the voltage on termination 4, this should be +1.8 - 2.3V for 30-40mV input and +9 - 9.7V for 40-55mV input.

UHF Tuner (440-800MHz Range)

Connect frequency counter 50Ω impedance to RF oscillator output socket on rear panel.

Set AFC to 'OFF'. Set 'FINE TUNE' to centre position, bandwidth to N1. AGC to 'OFF'. Bandswitch to R1. To gain access to the trimmers of this unit, it will be necessary to remove the 800-1000MHz tuner as described in the maintenance section.

1. Tune to 440MHz and adjust 2C28 to produce a reading on the frequency counter of 47.650MHz.
2. Tune to 800MHz and adjust 2RV4 to produce a reading on the frequency counter of 83.650MHz.

Repeat 1 and 2 as necessary until no further adjustment is required.

Check that the frequency coverage is smooth without any jumps over the range.

Connect the RF millivoltmeter to the junction of 2R13 and 2C19 and check that the oscillator output voltage is between 300mV and 700mV over the range.

Remove the RF millivoltmeter and connect a Signal Generator to Aerial Input socket (440-800MHz). Connect an Audio Output Meter to the 3Ω connections on the ancillary socket.

3. Set the Signal Generator to 770MHz with an output voltage of $20\mu\text{V}$ and adjust 2RV1, 2RV2 and 2RV3, for maximum reading on the Output Meter reducing the Signal Generator output voltage as necessary.
4. Set the Signal Generator to 470MHz with an output voltage of $20\mu\text{V}$ and adjust 2C5 and 2C14 for maximum audio output reducing Signal Generator output voltages as necessary.

Repeat 3 and 4 as necessary until no further adjustment is required.

Check that sensitivity over the range is of the order $6\mu\text{V}$ for a 10dB signal/noise ratio. Adjust 2RV2 if required to balance gain over complete range.

Check that the image rejection at 470MHz (+73MHz) and 770MHz (+73MHz) is better than 40dB.

Replace 800-1000MHz tuner unit.

UHF Tuner (800-1000MHz Range).

Connect frequency counter (50Ω impedance) to RF oscillator output socket on rear panel.

Set AFC to 'OFF'. Set 'FINE TUNE' to centre position. Bandwidth to 'NI' AGC to 'OFF'. Bandswitch to R2. To gain access to the trimmers of the unit it will be necessary to remove the 440-800MHz tuner as described in the maintenance section.

1. Tune to 800MHz and adjust 3C37 to produce a reading on the frequency counter of 83.650MHz.
2. Tune to 1000MHz and adjust 3RV4 to produce a reading on the frequency counter of 103.650MHz.

Repeat 1 and 2 as necessary until no further adjustment is required.

Check that the frequency coverage is smooth without any jumps over the range.

Connect the RF millivoltmeter to the junction of 3R13 (mixers end) and 3C17 and check that the oscillator output voltage is between 350mV and 800mV over the range.

Remove the RF millivoltmeter and connect a Signal Generator to Aerial Input Socket (800-1000MHz). Connect an Audio Output Meter to the 3Ω connections on the ancillary socket.

3. Set the Signal Generator to 980MHz with an output voltage of $20\mu\text{V}$ and adjust 3RV1, 3RV2 and 3RV3 for maximum reading on the Output Meter, reducing the Signal Generator output voltage as necessary.

4. Set the Signal Generator to 830MHz with an output voltage of $20\mu\text{V}$ and adjust 3C6, 3C11 and 3C13 for maximum audio output, reducing Signal Generator output voltage as necessary.

Repeat 3 and 4 as necessary until no further adjustment is required.

Check that the sensitivity over the range is of the order $6\mu\text{V}$ for a 10dB signal/noise ratio.

Check that the image rejection at 830MHz (+73MHz) and 980MHz (+73MHz) is better than -30dB.

Replace 440-800MHz tuner unit.

Oscillator \div 10 Unit

1. Connect Signal Generator to input socket 1 or 2. (SK7 or SK8).
2. Connect 50Ω input frequency counter to 'SYNC' output socket SK16.
3. Set Signal generator to 900MHz with an output voltage of 100mV p.d.
4. Switch on receiver and check that counter reads 90MHz.
5. Reduce signal generator output voltage until counter gives false reading and adjust 5C9 to restore true reading of 90MHz. Continue this process until no further adjustment is possible.
6. Check that sensitivity is within the limits 2-15mV for correct dividing.
7. Check at 400MHz and 1050MHz.
0.5-5mV 40-350mV.

Repeat 2 to 7 with counter in 'OSC' output socket. SK17.

Crystal Calibrator

Switch calibrator to 50MHz and check that crystal is oscillating.

Connect a frequency counter to gate 1 of 10TR1 (i.e. junction of 10R9 to R10 and 10C3) and adjust C2 to give a frequency of 50.0000MHz. Switch to 10MHz and check frequency is 10MHz. Check that the output is modulated at approx. 800Hz.

1990S INTEGRATED CIRCUITS

	1	2	3	4	5	6	7	8	9	10	11	12	13	14	15	16
1K1	+12.0V	+18.0V	0V	-	-	-	-	-	-	-	-	-	-	-	-	-
1K2	+5.0V	+12.0V	0V	-	-	-	-	-	-	-	-	-	-	-	-	-
5K1	0V	0V	0V	+5.4V	0V	0V	0V	0V	0V	+2.4V	0V	+2.5V	0V	+6.5V	-	
7K1	0V	+2.8V	+2.8V	+6.2V	+6.2V	0V	0V	-	-	-	-	-	-	-	-	-
7K2	-	+3.5V	0V	+2.8V	+7.0V	+10.0V	+10.0V	-	-	-	-	-	-	-	-	-
7K3	+1.8V	+1.8V	0V	0V	0V	+5.0V	+5.0V	+5.6V	+5.6V	+5.6V	+10V	-	+1.5V	0V	+4.6V	0V
8K1	+1.4V	+3.1V	+2.5V	+2.5V	+11.4V	+1.5V	+1.4V	+11.3V	+12.0V	+12.0V	+3.6V	+3.8V	-	-	-	-
8K2	+1.4V	+3.1V	+2.5V	+2.5V	+11.4V	+1.5V	+1.4V	+11.3V	+12.0V	+12.0V	+3.6V	+3.8V	-	-	-	-
9K1	0V	+6.4V	+1.8V	0V	+0.9V	+0.9V	0V	0V	-	-	-	-	-	-	-	-
9K2	0V	+6.4V	+2.0V	0V	+0.9V	+0.9V	0V	0V	-	-	-	-	-	-	-	-
9K3	0V	+6.4V	+2.1V	0V	+0.9V	+0.9V	0V	0V	-	-	-	-	-	-	-	-
10K1	+1.5V	+1.5V	+1.5V	+1.5V	+1.5V	+1.7V	0V	+1.5V	+1.7V	+1.7V	+1.9V	+1.4V	+1.5V	+4.9V	-	-
10K2	+4.9V	+1.0V	+4.9V	+4.9V	+3.5V	+1.9V	0V	+1.6V	+1.6V	+4.9V	+4.9V	+0.8V	+4.9V	+5.0V	-	-
11K1	-18.0V	+6.0V	+5.7V	-18.0V	-18.0V	+7.4V	+7.4V	+10.0V	-	-	-	-	-	-	-	-
12K1	-	+2.0V	+0.05V	0V	-	+2.0V	+10.0V	-	-	-	-	-	-	-	-	-
12K2	-	+6.2V	+2.0V	0V	+1.0V	+1.0V	0V	0V	-	-	-	-	-	-	-	-
13K1	+1.2V	0V	+2.2V	0V	0V	+24.0V	+11.5V	0V	0V	+11.5V	+0.2V	+1.65V	+11.5V	+11.7V	-	-
14K1	+11.8V	0V	+11.8V	0V	0V	+11.8V	+0.8V	+1.6V	+5.8V	+0.2V	0V	0V	0V	0V	0V	+6.0V
14K2	0V	0V	0V	+5.7V	0V	+5.2V	+5.7V	+10V	+11.8V	0V	+11.8V	0V	+5.8V	0V	0V	0V
16K1	-	-	-	+14.6V	+14.6V	+11.0V	-18.0V	-	+18.5V	-	+6.0V	+6.0V	+11.0V	-	-	-
16K2	-	-	-	+27.0V	+27.0V	+23.0V	-30.0V	-	+31.0V	-	+18.0V	+18.0V	+23.0V	-	-	-

1990S TRANSISTOR VOLTAGES

	e/s	b/g1	g2	c/d
2TR1	+1.9V	+2.65V	-	+9.8V
2TR2	0V	+2.2V	+3.0V	+10.0V
2TR3	+4.6V	+5.1V	-	+9.6V
2TR4	+1.3V	+1.8V		+6.7V
2TR5	+1.8V	+2.2V		+9.1V
3TR1	+1.75V	+2.5V	-	+9.8V
3TR2	0V	+2.2V	+2.9V	+10.0V
3TR3	+4.3V	+5.0V	-	+9.6V
3TR4	+1.3V	+2.1V	-	+6.5V
3TR5	+2.0V	+2.1V	-	+9.0V
5TR1	0 to +1.5V *	+3.2V	+1V to +7V *	+7.0V to +9.5V*
5TR2	+8.7V	+7.0V to +9.5V*	-	+9.6V
5TR3	+0.4V	+1.1V	-	+5.6V
5TR4	+0.5V to +9.0V	+10V to +11V	-	+9.8V
5TR5	+5.0V	+5.7V	-	+9.0V
6TR1	+0.25V	+1.4V	+3.0V	+10.0V
6TR2	+1.2V	0V	-	+10.0V
6TR3	+2.0V	0V	-	+10.0V
6TR4	+0.4V	+1.0V	-	+9.3V
6TR5	+10.0V	+9.3V	-	+3.0V
6TR6	+1.1V	0V	-	+10.0V
6TR7	+2.1V	0V	-	+10.0V
6TR8	+1.0V	0V	-	+10.0V
6TR9	+1.2V	+2.0V	-	+7.0V
7TR1	+3.0V	+3.6V	-	+9.5V
7TR2	+4.2V	+5.0V	-	+9.6V
7TR3	+1.9V	+2.3V	-	+5.7V
8TR1	+10.0V	-0.7V	-	+1.0V
8TR2	+0.1V	0V	-	+6.6V
8TR3	+1.2V	0V	-	+9.0V
8TR4	+0.75V	+1.45V	-	+11.25V
8TR5	0V	+0.75V	-	+7.3V
8TR6	+2.6V	+3.3V	-	+11.75V

*Voltages vary with freq.

	e/s	b/g1	g2	c/d
8TR7	+1.2V	0V	-	+9.0V
10TR1	+1.25V	+1.65V	+2.35V	+7.0V
10TR2	+1.75V	+2.3V	-	+5.5V
12TR1	+3.0V	+3.5V	-	+8.5V
12TR2	+3.0V	+3.7V	-	+9.6V
12TR3	+4.4V	+4.9V	-	+9.2V
14TR1	+1.5V	0V	-	+11.6V
16TR1	0V	+0.65V	-	+11.5V
16TR2	0V	+0.65V	-	+11.5V
16TR3	-18.0V	-19.5V	-	-28.5V
16TR4	-33.0V	-34.1V	-	-40.5V
16TR5	-19.5V	-28.5V	-	-18.5V
16TR6	-27.0V	-40.5V	-	-34.0V
17TR1	-0.6V	0V	-	+4.65V
17TR2	-5.3V	-4.6V	-	+4.9V

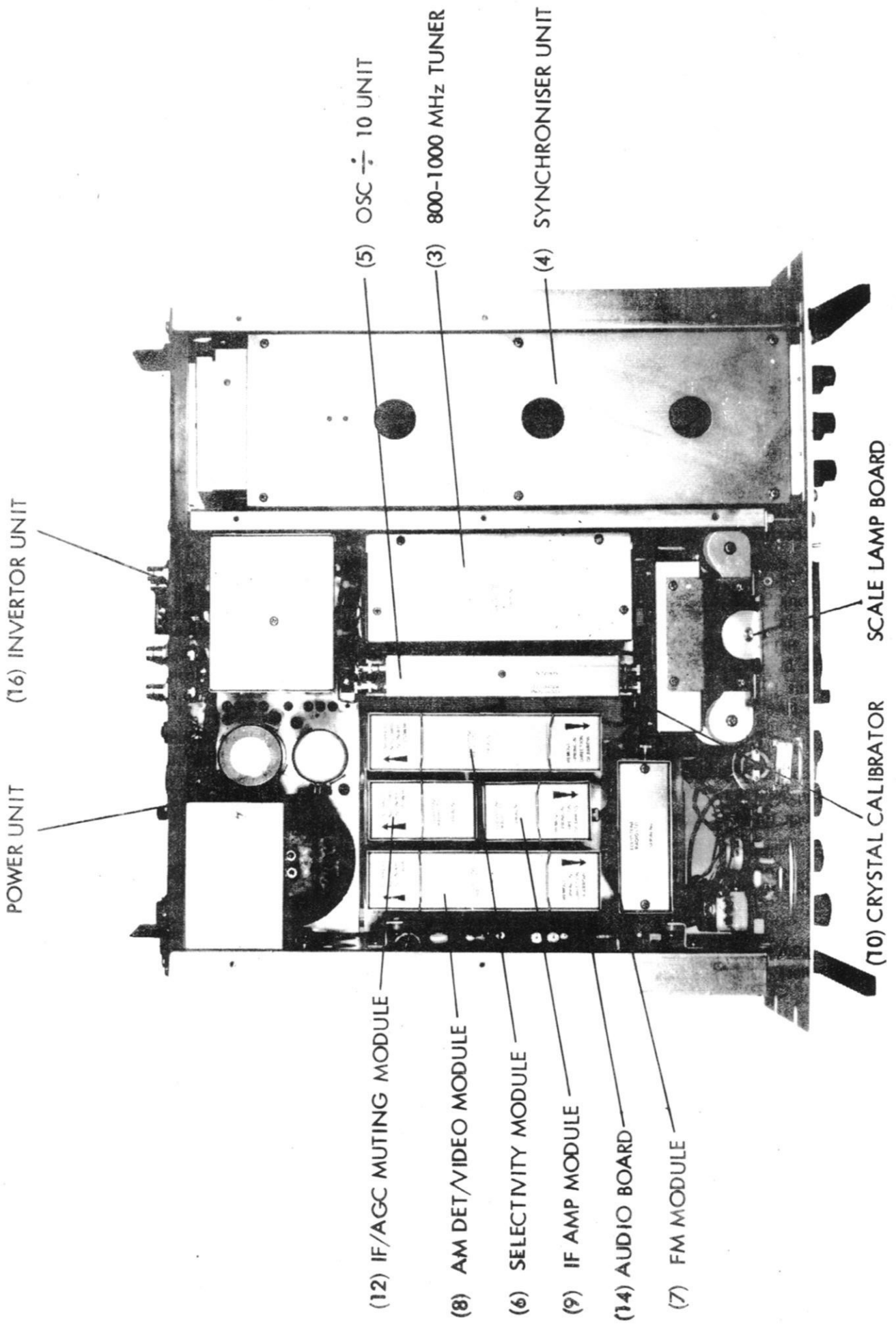

FIG 5-1 INTERNAL VIEW (TOP)

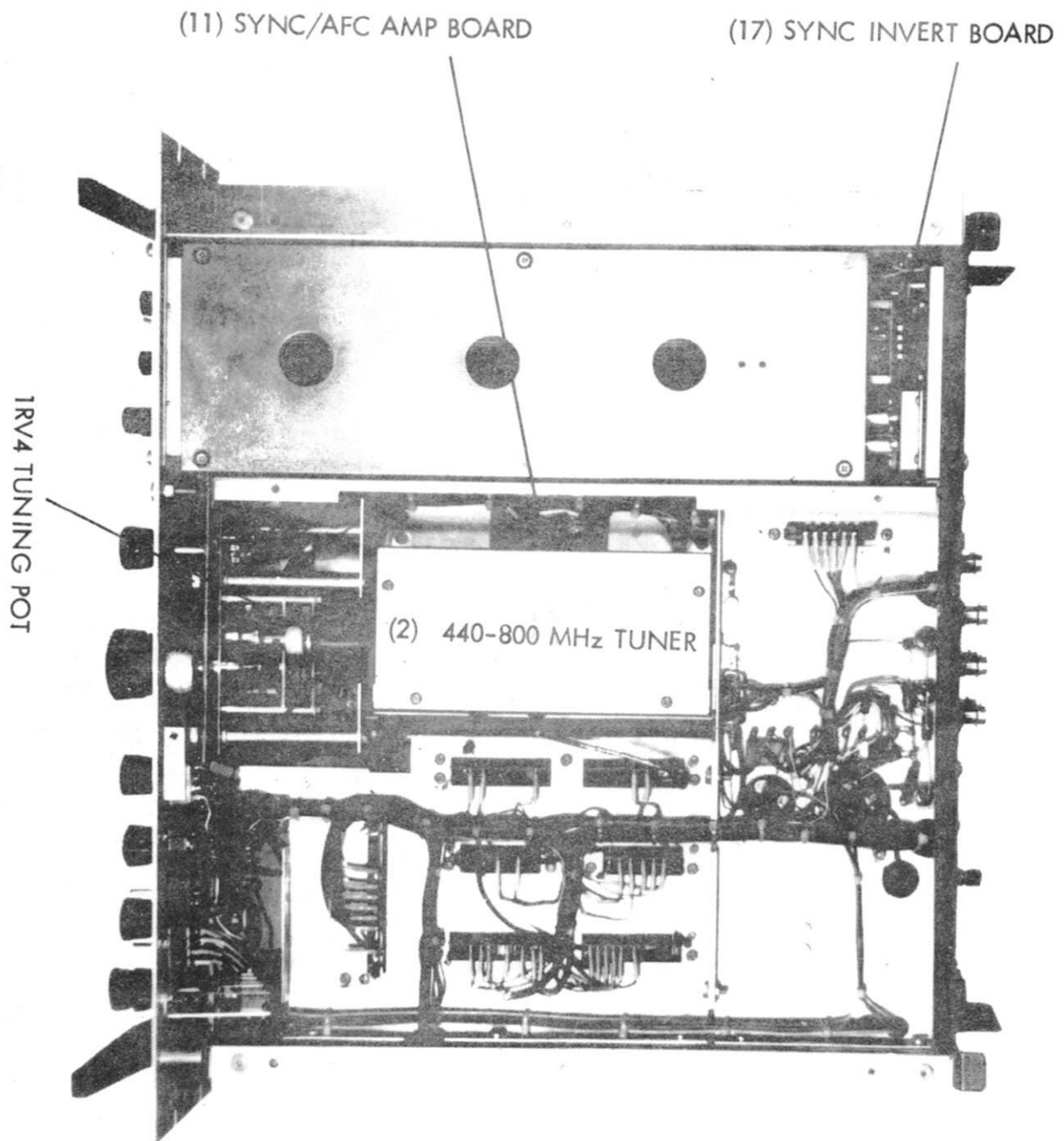
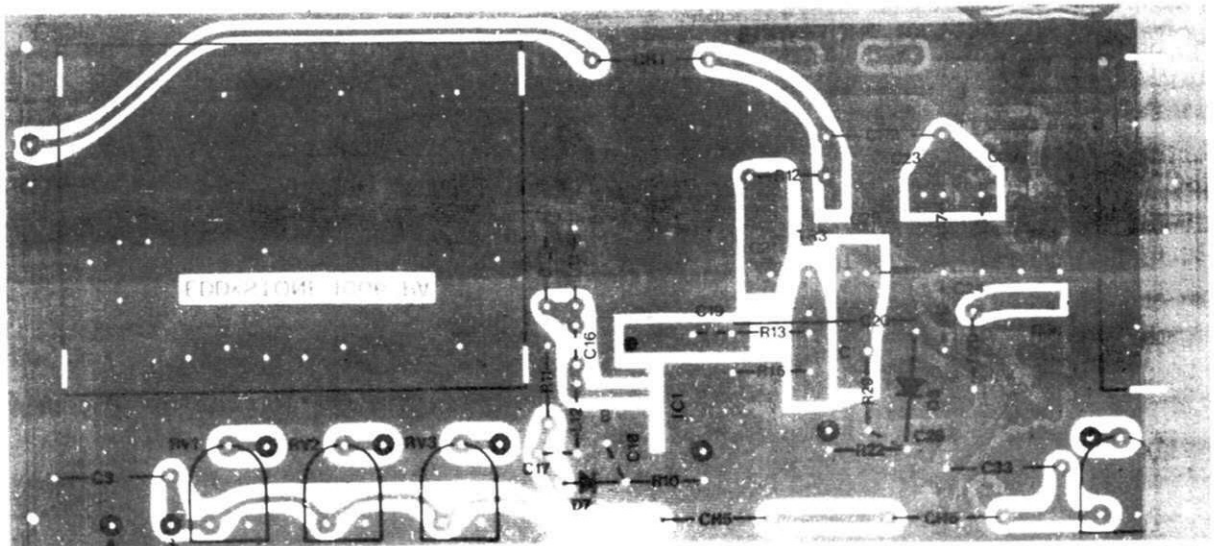
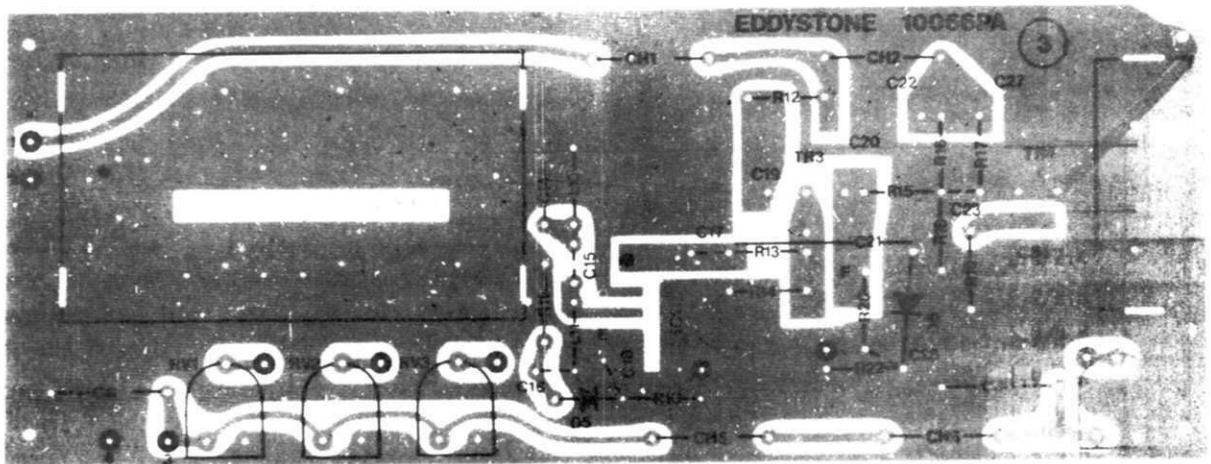

FIG 5-2 INTERNAL VIEW (BOTTOM)



(2) 440 - 800MHz TUNER UNIT



(3) 800 - 1000MHz TUNER UNIT

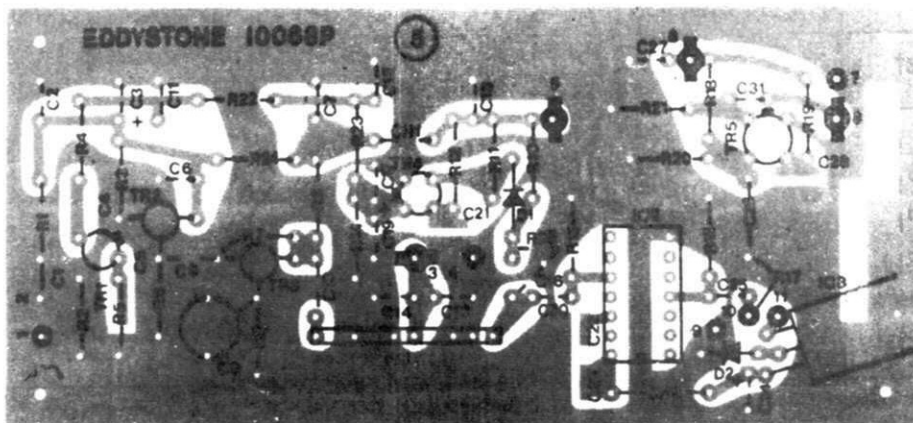

(5) OSCILLATOR DIVIDE BY 10 MODULE

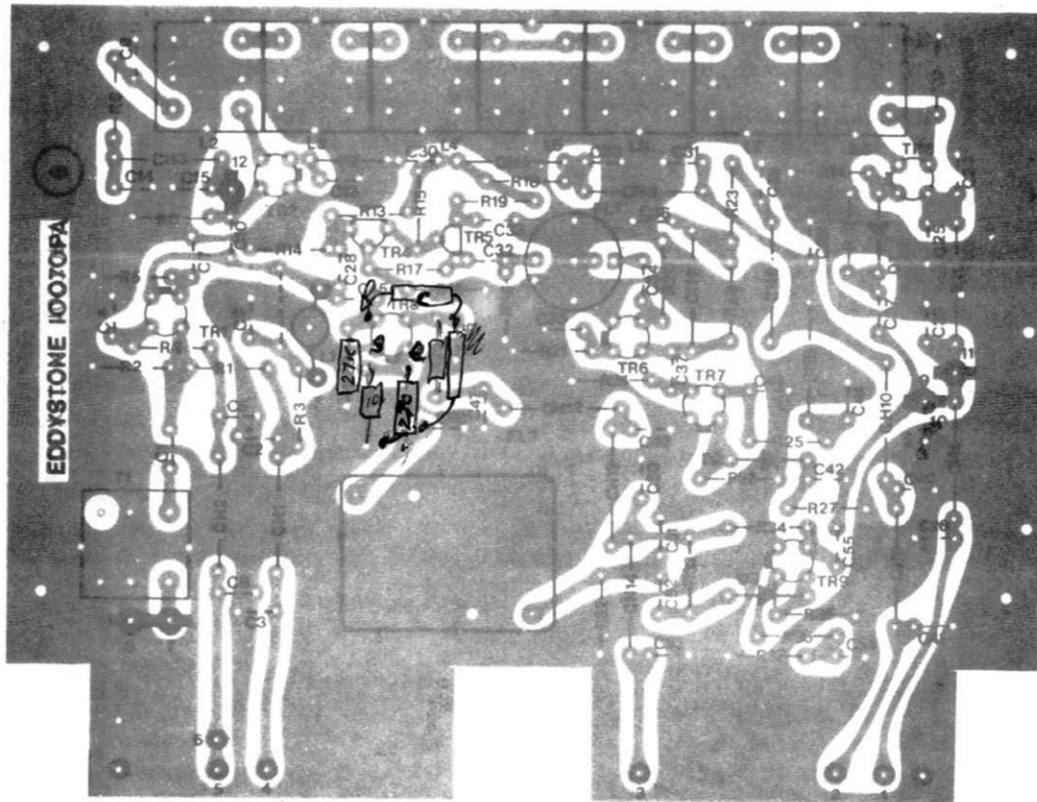

(6) SELECTIVITY MODULE

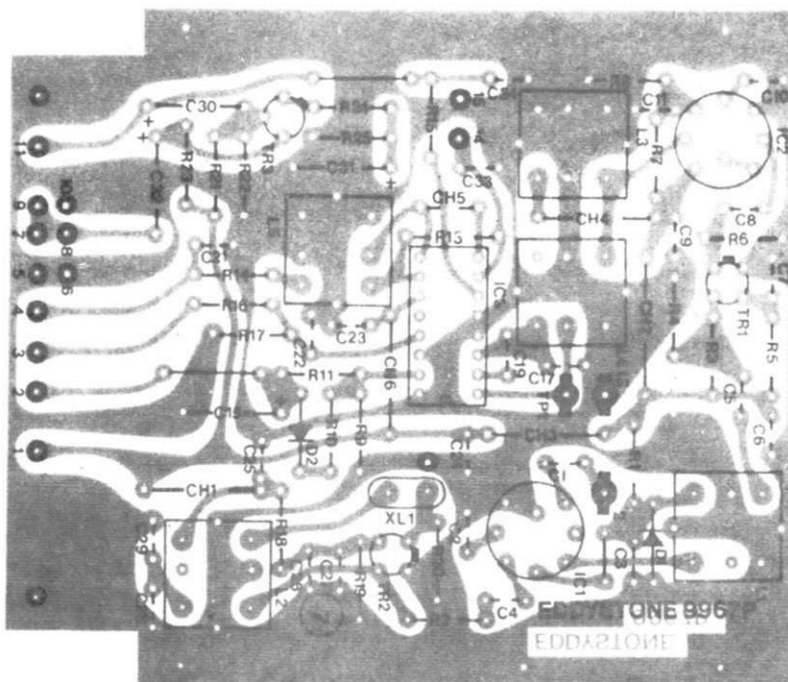

(7) FM MODULE

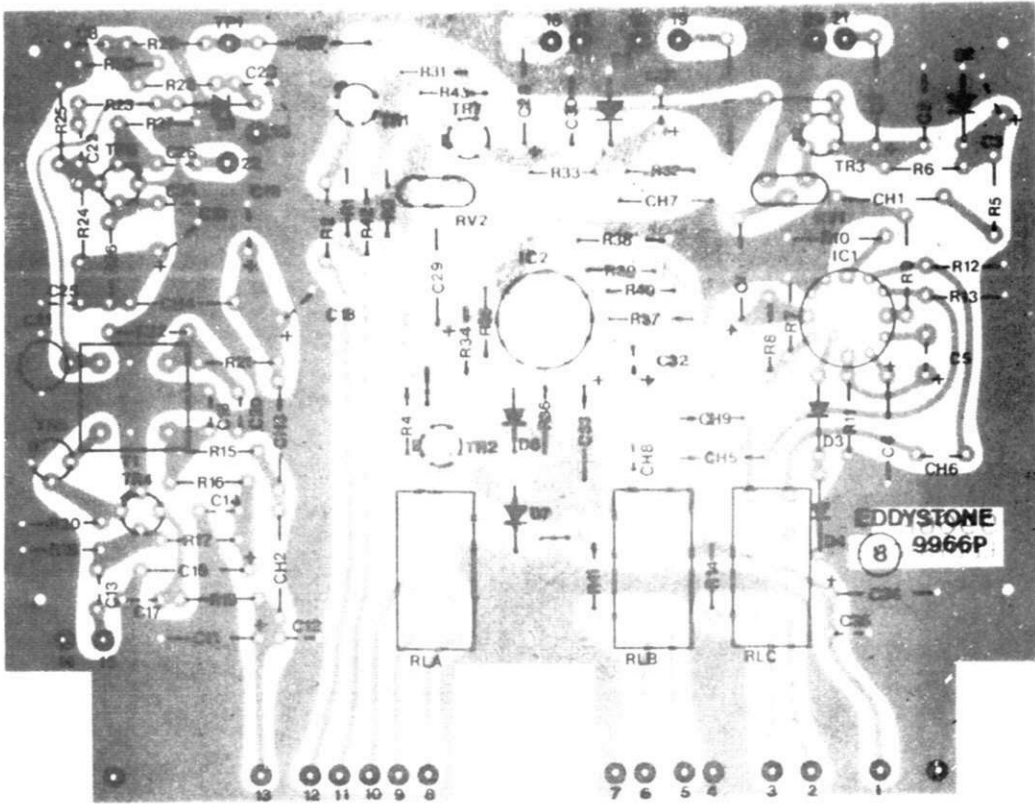

(8) AM DETECTOR & VIDEO MODULE

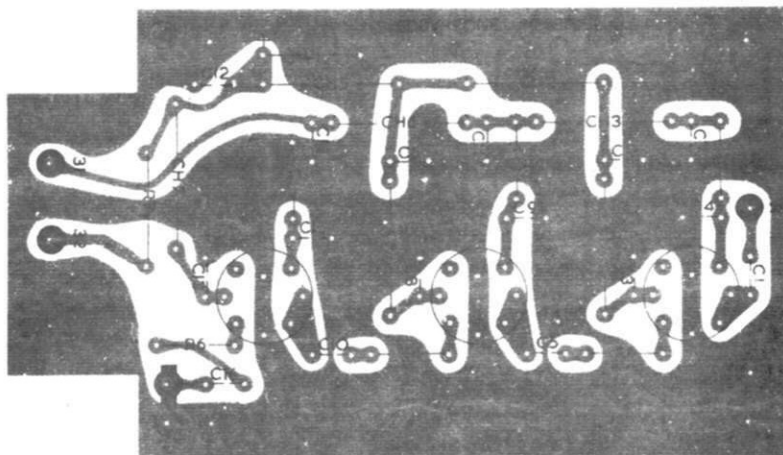

(9) AM IF AMPLIFIER MODULE

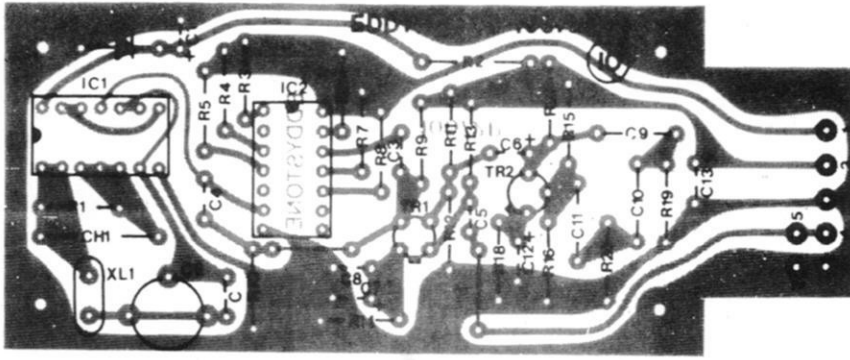

(10) CRYSTAL CALIBRATOR(S) UNIT

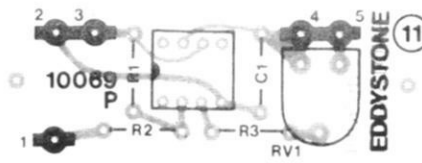

(11) SYNCHRONISER/AFC AMPLIFIER BOARD

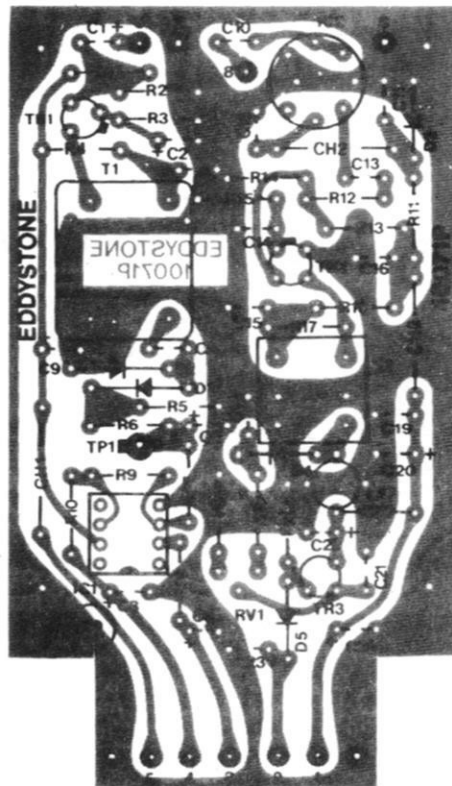

(12) IF AGC MUTING MODULE

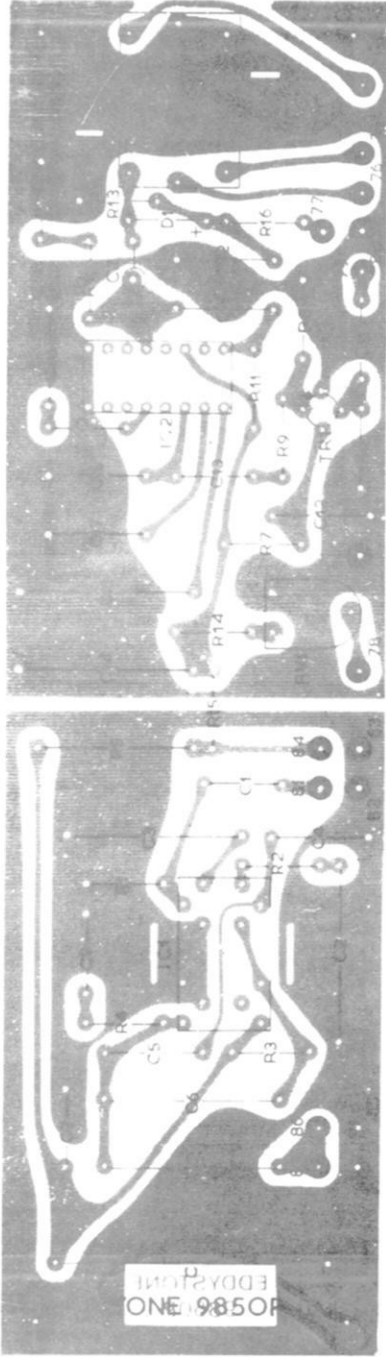

(14) AUDIO BOARD

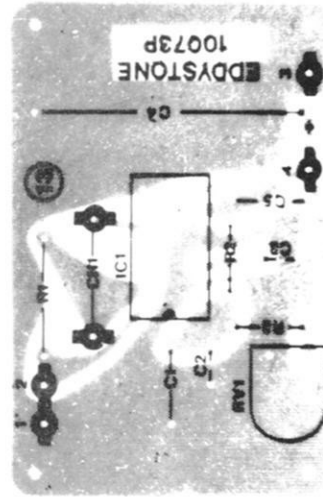

(13) 24V SWITCHED MODE BOARD

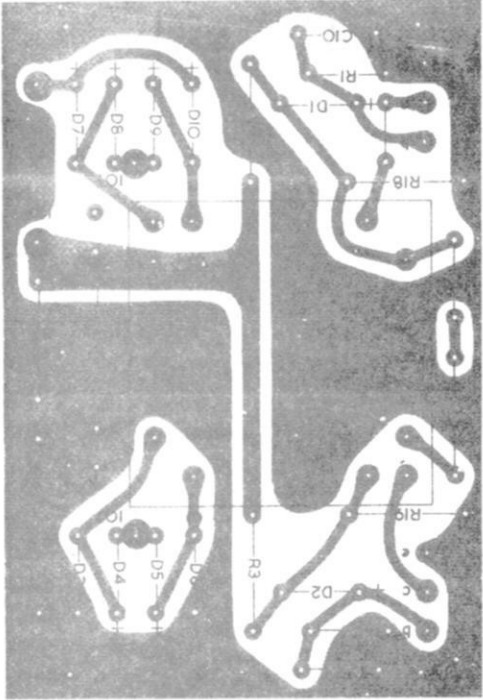

(16) INVERTOR OSC BOARD



LED MOUNTING BOARD



EDDYSTONE 52677



SCALE LAMP BOARD

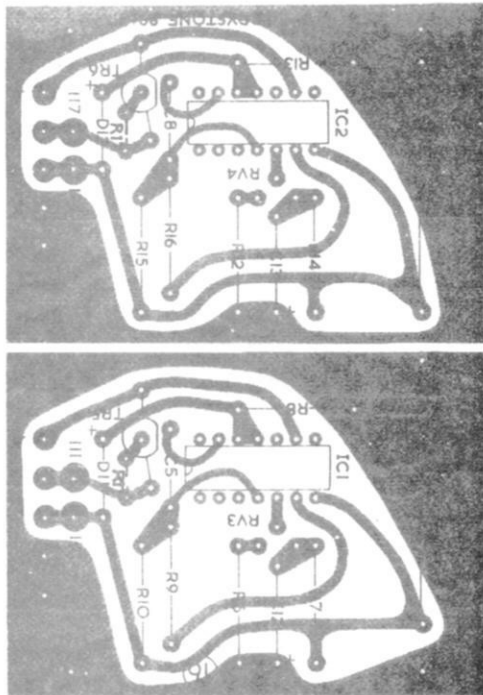

(16) INVERTOR REG BOARD

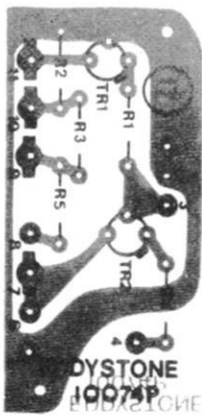

(17) SYNCHRONISER INVERT BOARD

Section 6

COMPONENTS LIST

LOCATION CODE

Each component reference in the Tables which follow is prefixed by a number which will assist in the location of the component. All components for a particular circuit module are uniquely identified by the prefix number which corresponds with the individual module number. The Coding is as follows:

- | | |
|-----------------------------------|--------------------------------------|
| 1. CHASSIS & MISCELLANEOUS | 11. SYNCHRONISER/AFC AMPLIFIER BOARD |
| 2. 440- 800MHz TUNER UNIT | 12. IF AGC MUTING MODULE |
| 3. 800-1000MHz TUNER UNIT | 13. 24V SWITCHED MODE BOARD |
| 4. (SYNCHRONISER HANDBOOK REFERS) | 14. AUDIO BOARD |
| 5. OSCILLATOR DIVIDE BY 10 MODULE | 15. POWER SUPPLIES |
| 6. SELECTIVITY MODULE | 16. VOLTAGE INVERTOR UNIT |
| 7. FM MODULE | 17. SYNCHRONISER INVERT BOARD |
| 8. AM DETECTOR & VIDEO MODULE | |
| 9. AM IF AMPLIFIER MODULE | |
| 10. CRYSTAL CALIBRATOR(S) UNIT | |

REPLACEMENT SPARES:

Spares should be ordered by quoting the complete circuit Reference, including the module prefix (where applicable), the component description and the part number where this is given in the lists.

From time to time, components of the type specified may be unavailable and in such circumstances equivalent types may be fitted or supplied as replacements. All orders and enquiries should be directed to the address below, quoting the type and Serial Numbers of the Equipment in all communications.

EDDYSTONE RADIO LIMITED
SALES AND SERVICE DEPT,
ALVECHURCH ROAD,
BIRMINGHAM B31 3PP.
ENGLAND.

TELEPHONE : 021-475-2231
TELEX: 337081
CABLES: EDDYSTONE BIRMINGHAM

Capacitors

Ref	Value	Type	Tolerance	Wkg. Voltage
1C 1)				
1C 2)				
1C 3)	NOT ALLOCATED			
1C 4)				
1C 5)				
1C 6	470m	Polycarbonate	20%	100V
1C 7	NOT ALLOCATED			
1C 8	10 μ	Tubular Electrolytic	20%	16V
1C 9	100 μ	Tubular Electrolytic	20%	16V
1C10	1n	Disc Ceramic	20%	500V
2C 1	15p	Tubular Ceramic	5%	200V
2C 2	15p	Tubular Ceramic	5%	200V
2C 3	1n	Disc Ceramic	20%	500V
2C 4	1n	Leadless Disc	20%	500V
2C 5	2p	Trimmer PTU/2/ST	0.2-2p	600V
2C 6	470p	Tubular Ceramic	10%	200V
2C 7	1n	Leadless Disc	20%	500V
2C 8	680n	Polycarbonate	20%	100V
2C 9	1n	Leadless Disc	20%	500V
2C10	1n	Leadless Disc	20%	500V
2C11	2p	Trimmer PTU/2/ST	0.2-2p	600V
2C12	1n	Disc Ceramic	20%	500V
2C13	1n	Leadless Disc	20%	500V
2C14	2p	Trimmer PTU/2/ST	0.2-2p	600V
2C15	15p	Tubular Ceramic	5%	200V
2C16	15p	Tubular Ceramic	5%	200V
2C17	100p	Tubular Ceramic	5%	200V
2C18	1n	Disc Ceramic	20%	500V
2C19	2p2	Tubular Ceramic	+0.5p	200V
2C20	8p2	Tubular Ceramic	5%	200V
2C21	1n	Leadless Disc	20%	500V
2C22	1n	Leadless Disc	20%	500V
2C23	1n	Leadless Disc	20%	500V
2C24	15p	Tubular Ceramic	5%	200V
2C25	1n	Leadless Disc	20%	500V
2C26	1n	Disc Ceramic	20%	500V
2C27	1n	Leadless Disc	20%	500V
2C28	2p	Trimmer PTU/2/ST	0.2-2p	600V
2C29	150 μ	Tantalum	20%	16V
2C30	1n	Disc Ceramic	20%	500V
2C31	1n	Disc Ceramic	20%	500V
2C32	1n	Leadless Disc	20%	500V
2C33	680n	Polycarbonate	20%	100V
2C34	1n	Leadless Disc	20%	500V
2C35	5p6	Tubular Ceramic	5%	200V
2C36	1n	Leadless Disc	20%	500V
2C37	1n	Disc Ceramic	20%	500V

Capacitors continued.....

Ref	Value	Type	Tolerance	Wkg. Voltage
3C 1	15p	Tubular Ceramic	5%	200V
3C 2	15p	Tubular Ceramic	5%	200V
3C 3	1n	Disc Ceramic	20%	500V
3C 4	1n	Leadless Disc	20%	500V
3C 5	2p2	Tubular Ceramic	10%	200V
3C 6	2p	Trimmer PTU/2/ST	0.2-2p	600V
3C 7	1n	Leadless Disc	20%	500V
3C 8	470n	Polycarbonate	20%	100V
3C 9	1n	Leadless Disc	20%	500V
3C10	1n	Leadless Disc	20%	500V
3C11	2p	Trimmer PTU/2/ST	0.2-2p	600V
3C12	1n	Disc Ceramic	20%	500V
3C13	2p	Trimmer PTU/2/ST	0.2-2p	600V
3C14	15p	Tubular Ceramic	5%	200V
3C15	15p	Tubular Ceramic	5%	200V
3C16	100p	Tubular Ceramic	5%	200V
3C17	2p2	Tubular Ceramic	+ 0.5p	200V
3C18	1n	Disc Ceramic	- 20%	500V
3C19	1n	Leadless Disc	20%	500V
3C20	1n	Leadless Disc	20%	500V
3C21	2p2	Tubular Ceramic	+ 0.5p	200V
3C22	1n	Leadless Disc	- 20%	500V
3C23	15p	Tubular Ceramic	5%	200V
3C24	150μ	Tantalum	20%	16V
3C25	1n	Leadless Disc	20%	500V
3C26	1n	Disc Ceramic	20%	500V
3C27	1n	Leadless Disc	20%	500V
3C28	2p2	Tubular Ceramic	+ 0.5p	200V
3C29	1n	Leadless Disc	- 20%	500V
3C30	470n	Polycarbonate	20%	100V
3C31	1n	Disc Ceramic	20%	500V
3C32	1n	Disc Ceramic	20%	500V
3C33	1n	Disc Ceramic	20%	500V
3C34	1n	Leadless Disc	20%	500V
3C35	22μ	Tantalum	20%	25V
3C36	15p	Tubular Ceramic	5%	200V
3C37	2p	Trimmer PTU/2/ST	0.2-2p	600V
4C	SYNCHRONISER MANUAL REFERS			
5C 1	1n	Disc Ceramic	20%	500V
5C 2	1n	Disc Ceramic	20%	500V
5C 3	150μ	Tantalum	20%	16V
5C 4	1n	Leadless Disc	20%	500V
5C 5	1n	Leadless Disc	20%	500V
5C 6	10n	Disc Ceramic	20%	500V
5C 7	1n	Disc Ceramic	20%	500V
5C 8	47p	Tubular Ceramic	5%	200V
5C 9	2p5/6p	Trimmer		160V

Ref	Value	Type	Tolerance	Wkg. Voltage
5C10	1n	Disc Ceramic	20%	500V
5C11	1n	Disc Ceramic	20%	500V
5C12	1n	Disc Ceramic	20%	500V
5C13	1n	Disc Ceramic	20%	500V
5C14	10n	Disc Ceramic	20%	500V
5C15				
5C16	100p	Tubular Ceramic	5%	200V
5C17	10n	Disc Ceramic	20%	500V
5C18	10n	Disc Ceramic	20%	500V
5C19	4 μ 7	Tantalum	20%	20V
5C20	1n	Disc Ceramic	20%	500V
5C21	1n	Leadless Disc	20%	500V
5C22	1n	Leadless Disc	20%	500V
5C23	1n	Leadless Disc	20%	500V
5C24	22 μ	Tubular Electrolytic	20%	16V
5C25	1n	Disc Ceramic	20%	500V
5C26	1n	Disc Ceramic	20%	500V
5C27	10n	Disc Ceramic	20%	500V
5C28	1n	Leadless Disc	20%	500V
5C29	1n5	Feedthrough capacitors		100V
5C30	1n5	Feedthrough capacitors		100V
5C31	1n	Disc Ceramic	20%	500V
5C32	220n	Polycarbonate		
5C33				
5C34	10n	Disc Ceramic	20%	500V
6C 1	10n	Disc Ceramic	20%	500V
6C 2	10n	Disc Ceramic	20%	500V
6C 3	10n	Disc Ceramic	20%	500V
6C 4	10n	Disc Ceramic	20%	500V
6C 5	10n	Disc Ceramic	20%	500V
6C 6	10n	Disc Ceramic	20%	500V
6C 7	10n	Disc Ceramic	20%	500V
6C 8	10n	Disc Ceramic	20%	500V
6C 9	10n	Disc Ceramic	20%	500V
6C10	27p	Tubular Ceramic	5%	200V
6C11	82p	Tubular Ceramic	5%	200V
6C12	10n	Disc Ceramic	20%	500V
6C13	10n	Disc Ceramic	20%	500V
6C14	10n	Disc Ceramic	20%	500V
6C15	10n	Disc Ceramic	20%	500V
6C16	12p	Tubular Ceramic	5%	200V
6C17	12p	Tubular Ceramic	5%	200V
6C18	82p	Tubular Ceramic	5%	200V
6C19	27p	Tubular Ceramic	5%	200V
6C20	27p	Tubular Ceramic	5%	200V
6C21	82p	Tubular Ceramic	5%	200V
6C22	82p	Tubular Ceramic	5%	200V
6C23	10n	Disc Ceramic	20%	500V

Capacitors continued.....

Ref	Value	Type	Tolerance	Wkg. Voltage
6C24	10n	Disc Ceramic	20%	500V
6C25	10n	Disc Ceramic	20%	500V
6C26	10n	Disc Ceramic	20%	500V
6C27	82p	Tubular Ceramic	5%	200V
6C28	27p	Tubular Ceramic	5%	200V
6C29	10n	Disc Ceramic	20%	500V
6C30	10n	Disc Ceramic	20%	500V
6C31	10n	Disc Ceramic	20%	500V
6C32	4n7	Plate Ceramic	10%	100V
6C33	150p	Tubular Ceramic	5%	200V
6C34	4n7	Plate Ceramic	10%	100V
6C35	10n	Disc Ceramic	20%	500V
6C36	10n	Disc Ceramic	20%	500V
6C37	1n	Disc Ceramic	20%	500V
6C38	10n	Disc Ceramic	20%	500V
6C39	10n	Disc Ceramic	20%	500V
6C40	10n	Disc Ceramic	20%	500V
6C41	10n	Disc Ceramic	20%	500V
6C42	82p	Tubular Ceramic	5%	200V
6C43	10n	Disc Ceramic	20%	500V
6C44	10n	Disc Ceramic	20%	500V
6C45	27p	Tubular Ceramic	5%	200V
6C46	10n	Disc Ceramic	20%	500V
6C47	10n	Disc Ceramic	20%	500V
6C48	10n	Disc Ceramic	20%	500V
6C49	27p	Tubular Ceramic	5%	200V
6C50	10n	Disc Ceramic	20%	500V
6C51	27p	Tubular Ceramic	5%	200V
6C52	82p	Tubular Ceramic	5%	200V
6C53	10n	Disc Ceramic	20%	500V
6C54	10n	Disc Ceramic	20%	500V
6C55	100p	Tubular Ceramic	5%	200V
6C56	10n	Disc Ceramic	20%	500V
6C57	10n	Disc Ceramic	20%	500V
7C 1	1n	Disc Ceramic	20%	500V
7C 2	10n	Disc Ceramic	20%	500V
7C 3	10n	Disc Ceramic	20%	500V
7C 4	1n	Disc Ceramic	20%	500V
7C 5	1n	Disc Ceramic	20%	500V
7C 6	10n	Disc Ceramic	20%	500V
7C 7	10n	Disc Ceramic	20%	500V
7C 8	1n	Disc Ceramic	20%	500V
7C 9	10n	Disc Ceramic	20%	500V
7C10	10n	Disc Ceramic	20%	500V
7C11	10n	Disc Ceramic	20%	500V
7C12	22μ	Tantalum	20%	20V
7C13	150p	Silver Mica	2%	350V
7C14	1p8	Disc Ceramic	+0.25p	100V

Capacitors continued.....

Ref	Value	Type	Tolerance	Wkg. Voltage
7C15	4 μ 7	Electrolytic		63V
7C16	10n	Disc Ceramic	20%	500V
7C17	10n	Disc Ceramic	20%	500V
7C18	150p	Silver Mica	2%	350V
7C19	10n	Disc Ceramic	20%	500V
7C20	47p	Silver Mica	2%	350V
7C21	10n	Disc Ceramic	20%	500V
7C22	10n	Disc Ceramic	20%	500V
7C23	10n	Disc Ceramic	20%	500V
7C24	10n	Disc Ceramic	20%	500V
7C25	10n	Disc Ceramic	20%	500V
7C26	10n	Disc Ceramic	20%	500V
7C27	1n	Disc Ceramic	20%	500V
7C28	10n	Disc Ceramic	20%	500V
7C29	1n	Disc Ceramic	20%	500V
7C30	1 μ	Electrolytic	20%	63V
7C31	22 μ	Electrolytic	20%	22V
7C32	1 μ	Electrolytic	20%	63V
7C33	10n	Disc Ceramic	20%	500V
8C 1	470n	Polycarbonate	20%	100V
8C 2	47n	Polycarbonate	20%	100V
8C 3	100 μ	Electrolytic	20%	25V
8C 4	10 μ	Electrolytic	20%	25V
8C 5	100 μ	Electrolytic	20%	25V
8C 6	10 μ	Electrolytic	20%	25V
8C 7	10 μ	Electrolytic	20%	25V
8C 8	22p	Tubular Ceramic	5%	200V
8C 9				
8C10	150 μ	Electrolytic	20%	16V
8C11	22 μ	Electrolytic	20%	25V
8C12	10n	Disc Ceramic	20%	500V
8C13	10n	Disc Ceramic	20%	500V
8C14	10n	Disc Ceramic	20%	500V
8C15	22 μ	Electrolytic	20%	25V
8C16	10n	Disc Ceramic	20%	500V
8C17	10n	Disc Ceramic	20%	500V
8C18	220 μ	Electrolytic	20%	16V
8C19	220 μ	Electrolytic	20%	16V
8C20	10n	Disc Ceramic	20%	500V
8C21	7235p	Trimmer		160V
8C22	3p	Tubular Ceramic	+ 0.5p	200V
8C23	15p	Tubular Ceramic	5%	200V
8C24	10n	Disc Ceramic	20%	500V
8C25	10n	Disc Ceramic	20%	500V
8C26	1n	Disc Ceramic	20%	500V
8C27	470n	Polycarbonate	20%	100V
8C28	10 μ	Electrolytic	20%	25V
8C29	10 μ	Electrolytic	20%	25V

Capacitors continued.....

Ref	Value	Type	Tolerance	Wkg. Voltage
8C30	47n	Polycarbonate	20%	100V
8C31	100 μ	Electrolytic	20%	25V
8C32	100 μ	Electrolytic	20%	25V
8C33	10 μ	Electrolytic	20%	25V
8C34	10 μ	Electrolytic	20%	25V
8C35	10n	Disc Ceramic	20%	500V
8C36	680n	Polycarbonate	20%	100V
9C 1	10n	Disc Ceramic	20%	500V
9C 2	10n	Disc Ceramic	20%	500V
9C 3	10n	Disc Ceramic	20%	500V
9C 4	10n	Disc Ceramic	20%	500V
9C 5	10n	Disc Ceramic	20%	500V
9C 6	10n	Disc Ceramic	20%	500V
9C 7	10n	Disc Ceramic	20%	500V
9C 8	10n	Disc Ceramic	20%	500V
9C 9	10n	Disc Ceramic	20%	500V
9C10	10n	Disc Ceramic	20%	500V
9C11	10n	Disc Ceramic	20%	500V
9C12	10n	Disc Ceramic	20%	500V
9C13	10n	Disc Ceramic	20%	500V
9C14	10n	Disc Ceramic	20%	500V
9C15	10n	Disc Ceramic	20%	500V
9C16	10n	Disc Ceramic	20%	500V
10C 1	10 μ	Tubular Electrolytic	20%	16V
10C 2	10-60p	Trimmer		250V
10C 3	12p	Tubular Ceramic	5%	200V
10C 4	12p	Tubular Ceramic	5%	200V
10C 5	22p	Tubular Ceramic	5%	200V
10C 6	1 μ	Tubular Electrolytic	20%	63V
10C 7	10 μ	Tubular Electrolytic	20%	16V
10C 8	10n	Disc Ceramic	20%	500V
10C 9	100n	Polycarbonate	20%	100V
10C10	100n	Polycarbonate	20%	100V
10C11	100n	Polycarbonate	20%	100V
10C12	10 μ	Tubular Electrolytic	20%	16V
10C13	22 μ	Tubular Electrolytic	20%	25V
10C14	1n	Disc Ceramic	20%	500V
11C 1	100n	Polycarbonate	20%	100V
12C 1	1 μ	Tubular Electrolytic	20%	63V
12C 2	22 μ	Tantalum	20%	16V
12C 3	1 μ	Tantalum	20%	63V
12C 4	3n2	Polystyrene	+2½%	125V
12C 5	10n	Disc Ceramic	-20%	500V
12C 6	1 μ	Tubular Electrolytic	20%	63V
12C 7	22 μ	Tubular Electrolytic	20%	16V

Capacitors Continued.....

Ref	Value	Type	Tolerance	Wkg. Voltage
12C 8	22 μ	Tubular Electrolytic	20%	16V
12C 9	68 μ	Tantalum	20%	16V
12C10	1n	Disc Ceramic	20%	500V
12C11	10n	Disc Ceramic	20%	500V
12C12	10n	Disc Ceramic	20%	500V
12C13	1n	Disc Ceramic	20%	500V
12C14	10n	Disc Ceramic	20%	500V
12C15	10n	Disc Ceramic	20%	500V
12C16	10n	Disc Ceramic	20%	500V
12C17	4p5/20p	Trimmer		160V
12C18	1n	Disc Ceramic	20%	500V
12C19	10n	Disc Ceramic	20%	500V
12C20	22 μ	Tubular Electrolytic	20%	16V
12C21	10n	Disc Ceramic	20%	500V
12C22	22 μ	Tubular Electrolytic	20%	16V
12C23	22 μ	Tubular Electrolytic	20%	16V
12C24	680n	Tantalum	20%	35V
13C 1	220n	Polycarbonate	20%	100V
13C 2	10n	Disc Ceramic	20%	500V
13C 3	1n	Disc Ceramic	20%	500V
13C 4	470 μ	Tubular Electrolytic	20%	25V
13C 5	100n	Polycarbonate	20%	100V
13C 6	220n	Polycarbonate	20%	100V
14C 1	100n	Polycarbonate	20%	100V
14C 2	220 μ	Electrolytic	20%	4V
14C 3	100 μ	Electrolytic	20%	10V
14C 4	3n9	Polystyrene	+2%	125V
14C 5	1n2	Polystyrene	+5%	125V
14C 6	100 μ	Tubular Electrolytic	20%	5V
14C 7	100n	Polycarbonate	20%	100V
14C 8	1000 μ	Electrolytic	20%	16V
14C 9	100n	Polycarbonate	20%	100V
14C10	220 μ	Tubular Electrolytic	+50%-10%	16V
14C11	47n	Polycarbonate	20%	100V
14C12	22 μ	Electrolytic	5%	25V
14C13	100n	Polycarbonate	20%	100V
14C14	220 μ	Electrolytic	20%	16V
14C15	4n7	Polystyrene	+5%	20V
14C16	100 μ	Tubular Electrolytic	+50%-10%	10V
14C17	22 μ	Tubular Electrolytic	+50%-10%	25V
14C18	47 μ	Electrolytic	+50%-10%	10V
14C19	22 μ	Electrolytic	+50%-10%	25V
14C20	150 μ	Electrolytic	+50%-10%	16V
14C21	150n	Polycarbonate	20%	100V
14C22	22 μ	Electrolytic	+50%-10%	25V

Capacitors continued.....

Ref	Value	Type	Tolerance	Wkg. Voltage
15C 1	7500 μ	Tubular Electrolytic	20%	25V
15C 2	7500 μ	Tubular Electrolytic	20%	25V
15C 3	7500 μ	Tubular Electrolytic	20%	16V
15C 4	7500 μ	Tubular Electrolytic	20%	16V
15C 5	47n	Polycarbonate	20%	250V
15C 6	NOT ALLOCATED			
15C 7	470n	Polycarbonate	20%	100V
15C 8	NOT ALLOCATED			
15C 9	10 μ	Electrolytic	20%	16V
15C10	NOT ALLOCATED			
15C11	100n	Polycarbonate	20%	100V
15C12	100n	Polycarbonate	20%	100V
15C13	100n	Polycarbonate	20%	100V
16C 1	470n	Polycarbonate	20%	100V
16C 2	100 μ	Tubular Electrolytic	+50%-10%	25V
16C 3	100n	Polycarbonate	20%	100V
16C 4	2200 μ	Tubular Electrolytic	+50%-10%	40V
16C 5	100p	Polystyrene	5%	125V
16C 6	100 μ	Tubular Electrolytic	+50%-10%	25V
16C 7	1000 μ	Tubular Electrolytic	+50%-10%	63V
16C 8	100p	Polystyrene	5%	125V
16C 9	680 μ	Tubular Electrolytic	+50%-10%	40V
16C10	100n	Polycarbonate	20%	100V
16C11	100n	Polycarbonate	20%	100V
16C12	3 μ 3	Tantalum	20%	35V
16C13	3 μ 3	Tantalum	20%	35V

Resistors

All resistors are 5% tolerance 0.3W rating CR25 unless otherwise stated.

Ref	Value Ohms	Rating W
1R 1	10k	
1R 2	22	
1R 3	3k3	
1R 4	18k	
1R 5	22k	
1R 6	5k6	
1R 7	27k	
1R 8	47k	
1R 9	1k	
1R10	680	
1R11	220k	
1R12	180k	
1R13		

Ref	Value Ohms	Rating W
1R14	680	
1R15	4k7	
2R 1	6k8	
2R 2	2k7	
2R 3	220	
2R 4	150k	
2R 5	47k	
2R 6	100k	
2R 7	220k	
2R 8	220k	
2R 9	220k	
2R10	470	

Resistors continued.....

Ref	Value Ohms	Rating W
2R11	470	
2R12	33	
2R13	10	
2R14	470	
2R15	220	
2R16	10	
2R17	1k	
2R18	470	
2R19	1k	
2R20	150	
2R21	47	
2R22	470	
2R23	220k	
2R24	4k7	
2R25	150	
2R26	100	
2R27	5k6	
2R28	2k2	
2R29	22	
2R30	47A.O.T.	
3R 1	6k8	
3R 2	2k7	
3R 3	220	
3R 4	150k	
3R 5	47k	
3R 6	100k	
3R 7	220k	
3R 8	220k	
3R 9	220k	
3R10	470	
3R11	470	
3R12	33	
3R13	10	
3R14	220	
3R15	10	
3R16	1k	
3R17	470	
3R18	1k	
3R19	150	
3R20	47	
3R21	150	
3R22	470	
3R23	100	
3R24	2k2	
3R25	5k6	
3R26	470	
3R27	not fitted	

Ref	Value Ohms	Rating W
3R28	220	
3R29	22	
3R30	47	
3R31	680	
4R	Synchroniser manual refers.	
5R 1	47k	
5R 2	27k	
5R 3	100	
5R 4	47	
5R 5	68	
5R 6	2k2	
5R 7	33k	
5R 8	560	
5R 9	47	
5R10	22k	
5R11	100k	
5R12	47	
5R13	470k A. O. T.	
5R14	3k3	
5R15	15k	
5R16	2k7	
5R17	470	
5R18	820	
5R19	33	
5R20	1k2	
5R21	220	
5R22	47	
5R23	47	
5R24	100	
5R25	47	
6R 1	470k	
6R 2	100k	
6R 3	100	
6R 4	100k	
6R 5	68	
6R 6	100k	
6R 7	220	
6R 8	100	
6R 9	100k	
6R10	100	
6R11	2k2	
6R12	2k2	
6R13	10k	
6R14	1k2	

Resistors continued.....

Ref	Value Ohms	Rating W
6R15	470	
6R16	39	
6R17	470	
6R18	1k	
6R19	47	
6R20	330	
6R21	220	
6R22	1k	
6R23	100	
6R24	100k	
6R25	100	
6R26	2k2	
6R27	2k2	
6R28	100	
6R29	100k	
6R30	220	
6R31	100	
6R32	270	
6R33	1k5	
6R34	1k	
6R35	470	
6R36	120	
6R37	220	
6R38	330	
7R 1	150	
7R 2	100	
7R 3	3k3	
7R 4	3k3	
7R 5	100	
7R 6	820	
7R 7	1k	
7R 8	2k2	
7R 9	10k	
7R10	2k2	
7R11	22k	
7R12	4k7	
7R13	4k7	
7R14	47k	
7R15	2k7	
7R16	22k	
7R17	10k	
7R18	22k	
7R19	10k	
7R20	680	
7R21	22k	
7R22	6k8	
7R23	5k6	

Ref	Value Ohms	Rating W
7R24	100	
7R25	2k2	
8R 1	27k	
8R 2	5k6	
8R 3	100k	
8R 4	10	
8R 5	150	
8R 6	470	
8R 7	1k	
8R 8	10k	
8R 9	47	
8R10	47	
8R11	4k7	
8R12	82	
8R13	82	
8R14	560	
8R15	150	
8R16	2k7	
8R17	2k2	
8R18	1k2	
8R19	470	
8R20	470	
8R21	8k2	
8R22	100	
8R23	1k2	
8R24	1k5	
8R25	560	
8R26	22	
8R27	120	
8R28	3k3	
8R29	4k7	
8R30	6k8	
8R31	100k	
8R32	150	
8R33	470	
8R34	10k	
8R35	1k	
8R36	4k7	
8R37	47	
8R38	47	
8R39	82	
8R40	82	
8R41	560	
8R42	100k	
8R43	100k	

Resistors continued.....

Ref	Value Ohms	Rating W
9R 1	100	
9R 2	1k	
9R 3	100	
9R 4	100	
9R 5	1k	
9R 6	100	
9R 7	47	
10R 1	390	
10R 2	100	
10R 3	1k5	
10R 4	1k5	
10R 5	1k5	
10R 6	1k5	
10R 7	1k5	
10R 8	1k5	
10R 9	15k	
10R10	3k3	
10R11	10k	
10R12	3k3	
10R13	470	
10R14	220	
10R15	4k7	
10R16	1k5	
10R17	820	
10R18	330	
10R19	560	
10R20	560	
11R 1	10k	
11R 2	4k7	
11R 3	4k7	
12R 1	10k	
12R 2	10k	
12R 3	470	
12R 4	100	
12R 5	470k	
12R 6	100k	
12R 7	100	
12R 8	100k	
12R 9	4M7	
12R10	1k	
12R11	150	
12R12	470	
12R13	1k2	
12R14	680	
12R15	150	

Ref	Value Ohms	Rating W
12R16	47	
12R17	100	
12R18	2k2	
12R19	22k	
12R20	470	
12R21	1k	
13R 1	3R3 (w.w.)	W21 3W
13R 2	22k	
13R 3	820	
14R 1	100k	
14R 2	39	
14R 3	100	
14R 4	10	
14R 5	2k2	
14R 6	47k	
14R 7	100	
14R 8	470	
14R 9	2k2	
14R10	82	
14R11	100	
14R12	10	
14R13	2k2	
14R14	22k	
14R15	100	
14R16	6k8	
15R 1)		
15R 2)		
15R 3)		
15R 4)		
15R 5)		
15R 6)		
15R 7)	NOT ALLOCATED	
15R 8)		
15R 9)		
15R10)		
15R11)		
15R12)		
15R13)		
15R14)		
15R15)		
15R16	12 (w.w.)	W22 6W
15R17	5 (w.w.)	W21 3W
15R18	5 (w.w.)	W21 3W

Resistors continued.....

Ref	Value Ohms	Rating W
16R 1	1k	
16R 2	470 *	0.5W
16R 3	330 *	0.5W
16R 4	22 *	0.5W
16R 5	1k	
16R 6	4k7 *	0.1W
16R 7	820 *	0.1W
16R 8	680 *	0.5W
16R 9	3k3 *	0.1W
16R10	3k3 *	0.1W
16R11	1k	

Ref	Value Ohms	Rating W
16R12	15k *	0.1W
16R13	1k5 *	0.5W
16R14	1k8 *	0.1W
16R15	3k9 *	0.1W
16R16	3k9 *	0.1W
16R17	1k	
16R18	56	
16R19	56	
17R 1	33k	

- * 16R6, 16R7, 16R9, 16R10, 16R12, 16R14, 16R15, 16R16 are rated 0.1W high stability.
 10R2, 16R2, 16R3, 16R8, 16R13 are rated 0.5W.
 13R1, 15R17, 15R18 are rated 3W (wire wound).
 15R16 is rated 6W (wire wound).

Potentiometers

Ref	Value	Law	Type	Function
1RV 1	10k	Lin.	Pre-set	Meter Zero
1RV 2	50k	Log.	Pot	AF Gain
1RV 3	47k	Lin.	Pre-set	Line Level
1RV 4	100k	Lin.	10 T Pot	Tuning
1RV 5	10k	Lin.	Pot	Fine Tune
1RV 6	1k	Lin.	Pot)	IF Gain
1RV 7	50k	Lin.	Pot) Concentric	RF Gain
1RV 8	10k	Lin.	Pre-set	Muting Level
1RV 9	10k	Lin.	Pre-set	AFC/Sync Balance
1RV10	10k	Lin.	Pre-set	AFC/Sync Balance
2RV 1	470k	Lin.	Pre-set	Tuning Voltage Adjust
2RV 2	470k	Lin.	Pre-set	Tuning Voltage Adjust
2RV 3	470k	Lin.	Pre-set	Tuning Voltage Adjust
2RV 4	470k	Lin.	Pre-set	Tuning Voltage Adjust
3RV 1	470k	Lin.	Pre-set	Tuning Voltage Adjust

Potentiometers continued.....

Ref	Value	Law	Type	Function
3RV 2	470k	Lin.	Pre-set	Tuning Voltage Adjust
3RV 3	470k	Lin.	Pre-set	Tuning Voltage Adjust
3RV 4	470k	Lin.	Pre-set	Tuning Voltage Adjust
4RV	SYNCHRONISER MANUAL REFERS			
8RV 1	470Ω	Lin.	Pre-set	FM Video output level
8RV 2	470Ω	Lin.	Pre-set	AM Video output level
11RV 1	100k	Lin.	Pre-set	Set AFC level
12RV 1	47k	Lin.	Pre-set	Set IF AGC DC level
13RV 1	470Ω	Lin.	Pre-set	Set +24V
14RV 1	10k	Lin.	Carbon pre-set	AF Meter Zero Set
15RV 1	10k	Lin.	Pre-set	
15RV 2	50k	Lin.	Pre-set	
15RV 3	47k	Lin.	Pre-set	
16RV 1	-			
16RV 2	-			
16RV 3	470	Lin.	Cermet pre-set	-18V Adj.
16RV 4	470	Lin.	Cermet pre-set	-33V Adj.

Thermistors

Ref	Type
1TH1	VA1066S

Diodes

Ref	Type	Manufacturer	Circuit Function
1D 6	5082-4100	H. Packard	Range Indicator Lamp
1D 7	5082-4100	H. Packard	Range Indicator Lamp
2D 1	BB105B	Mullard	Tuning Varicap
2D 2	BB105B	Mullard	Tuning Varicap
2D 3	BB105B	Mullard	Tuning Varicap
2D 4	BB105B	Mullard	Tuning Varicap
2D 5	BB105B	Mullard	Tuning Varicap
2D 6	BB105B	Mullard	Tuning Varicap

Diodes continued.....

Ref	Type	Manufacturer	Circuit Function
2D 7	5082-3188	H. Packard	Switching Diode
2D 8	5082-3188	H. Packard	Switching Diode
2D 9	BB105B	Mullard	Tuning Varicap
2D10	BB105B	Mullard	Tuning Varicap
3D 1	BB105B	Mullard	Tuning Varicap
3D 2	BB105B	Mullard	Tuning Varicap
3D 3	BB105B	Mullard	Tuning Varicap
3D 4	BB105B	Mullard	Tuning Varicap
3D 5	5082-3188	H. Packard	Switching Diode
3D 6	5082-3188	H. Packard	Switching Diode
4D	SYNCHRONISER MANUAL REFERS		
5D 1	5082-2800	H. Packard	AGC Rectifier
5D 2	IN4004	Mullard	DC Level
6D 1	BAX13	Mullard	IF 'NI' Switching Diode
6D 2	BAX13	Mullard	IF 'W' Switching Diode
6D 3	BAX13	Mullard	IF 'N2' Switching Diode
7D 1	BZX79C6V2	Mullard	Zener
7D 2	BAX13	Mullard	RF AGC Delay
8D 1	0A47	Mullard	AM Detector
8D 2	BZX79C10	Mullard	Zener
8D 3	IN4004	Mullard	Video DC Level
8D 4	IN4004	Mullard	Video DC Level
8D 5	BZX79C10	Mullard	Zener
8D 6	IN4004	Mullard	Video DC Level
8D 7	IN4004	Mullard	Video DC Level
9D 1	BZX79C6V2	Mullard	Zener
10D 1	BZX79C5V1	Mullard	Zener
12D 1	0A47	Mullard	Muting Noise Rectifier
12D 2	0A47	Mullard	Muting Noise Rectifier
12D 3	BZX79C6V2	Mullard	Zener
12D 4	5082-2800	H. Packard	IF AGC Rectifier
12D 5	BAX13	Mullard	IF AGC Clamp
14D 1	0A47	Mullard	AF Meter Rectifier
15D 1	BYW21	Mullard	Bridge Rectifier
15D 2	IN4004	Mullard	Reverse Voltage Protection
15D 3	BZY93/C10	Mullard	10V Zener
15D 4	BZY93/C10	Mullard	10V Zener
15D 5	BZY93/C10	Mullard	10V Zener

Diodes continued.....

Ref	Type	Manufacturer	Circuit Function
16D 1	BAV10	Mullard	Clamp
16D 2	BAV10	Mullard	Clamp
16D 3	BY210-400	Mullard)	Bridge Rectifier
16D 4	BY210-400	Mullard)	
16D 5	BY210-400	Mullard)	
16D 6	BY210-400	Mullard)	
16D 7	BY210-400	Mullard)	
16D 8	BY210-400	Mullard)	
16D 9	BY210-400	Mullard)	Bridge Rectifier
16D10	BY210-400	Mullard)	
16D11	BZY88C12	Mullard	Zener
16D12	BZY88C12	Mullard	Zener

Transistors

Ref	Type	Manufacturer	Circuit Function
2TR 1	BFR90	Mullard	RF Amplifier
2TR 2	SD308DC	Mullard	RF Amplifier
2TR 3	BFR96	Mullard	Oscillator Buffer
2TR 4	BRF90	Mullard	Oscillator Amplifier
2TR 5	BFR90	Mullard	RF Oscillator
3TR 1	BFR90	Mullard	RF Amplifier
3TR 2	SD308DC	Mullard	RF Amplifier
3TR 3	BFR96	Mullard	Oscillator Buffer
3TR 4	BFR90	Mullard	Oscillator Amplifier
3TR 5	BFR90	Mullard	RF Oscillator
4TR	SYNCHRONISER MANUAL REFERS		
5TR 1	SD308DC	Mullard	Wide Band Amplifier
5TR 2	BFR90	Mullard	Wide Band Amplifier
5TR 3	BFR90	Mullard	Wide Band Amplifier
5TR 4	E270	Siliconix	AGC Amplifier
5TR 5	BFW30	Mullard	Output Buffer
6TR 1	SD306	Mullard	IF Pre-amplifier
6TR 2	UC734B	Union Carbide	IF 'N1' Amplifier
6TR 3	UC734B	Union Carbide	IF 'N1' Buffer
6TR 4	BF197	Mullard	IF 'W' Amplifier
6TR 5	BF324	Mullard	IF 'W' Amplifier
6TR 6	UC734B	Union Carbide	IF 'W' Amplifier
6TR 7	UC734B	Union Carbide	IF 'W' Buffer
6TR 8	UC734B	Union Carbide	IF 'N2' Amplifier
6TR 9	BFX89	Mullard	IF 'N2' Amplifier

Transistors continued.....

Ref	Type	Manufacturer	Circuit Function
7TR 1	BFX89	Mullard	FM Buffer
7TR 2	BFX89	Mullard	FM Oscillator
7TR 3	BC107B	Mullard	FM Audio Pre-amp
8TR 1	BCY71	Mullard	Muting
8TR 2	UC734B	Union Carbide	Muting Relay Switch
8TR 3	UC734B	Union Carbide	FM Audio/Video Splitter
8TR 4	BFX89	Mullard	AM IF Buffer Amp
8TR 5	2N3866	Mullard	AM IF Amplifier
8TR 6	BFX89	Mullard	IF Output Buffer
8TR 7	UC734B	Union Carbide	AM Audio/Video Splitter
10TR 1	40673	RCA	Calibrator Mixer
10TR 2	BC107B	Mullard	Calibrator Audio Oscillator
12TR 1	BC107B	Mullard	Muting Noise Amp
12TR 2	BFX89	Mullard	AGC Amplifier
12TR 3	BC107B	Mullard	AGC DC Level
14TR 1	UC734B	Union Carbide	Line Audio Preamplifier
16TR 1	BDX36	Mullard)	Square-wave Oscillator
16TR 2	BDX36	Mullard)	
16TR 3	2N4918	Motorola	Voltage Regulator
16TR 4	2N4919	Motorola	Voltage Regulator
16TR 5	BF245B	Mullard	Current Source
16TR 6	BF245B	Mullard	Current Source
17TR 1	BC107B	Mullard	Sync Invertor
17TR 2	BC107B	Mullard	Sync Invertor

Integrated Circuits

Ref	Type	Manufacturer	Circuit Function
2IC 1	5082-9200	H. Packard	Single Balanced Mixer 440/800MHz
3IC 1	5082-9200	H. Packard	Single Balanced Mixer 800/1000MHz
4IC	SYNCHRONISER MANUAL REFERS		
5IC 1	OM335	Mullard	÷ 10 Wide band amplifier
5IC 2	SP8667B or SP8666B	Plessey	÷ 10 Synchroniser prescaler
5IC 3	MC7805CT	Fairchild	Voltage Regulator

Ref	Type	Manufacturer	Circuit Function
7IC 1	SL641C	Plessey	Balanced Mixer
7IC 2	CA3028A	RCA	FM Input Amplifier
7IC 3	CA3089E	RCA	FM Amp/Discriminator
8IC 1	CA3020A	RCA	Video Amplifier
8IC 2	CA3020A	RCA	Video Amplifier
9IC 1	SL611C	Plessey	IF Amplifier
9IC 2	SL610C	Plessey	IF Amplifier
9IC 3	SL610C	Plessey	IF Amplifier
10IC 1	SN74S00N	Texas	Cal. Xtal Oscillator
10IC 2	SN74S196N	Texas	Cal. $\div 5$
11IC 1	$\mu 741$	Texas	Sync/AFC Amplifier
12IC 1	$\mu 741p$	Texas	Schmitt-Trigger
12IC 2	SL611C	Plessey	AGC Amplifier
13IC 1	TL497CN	Texas	Switched Mode Invertor
14IC 1	TBA810S	SGS	Main Audio Amplifier
14IC 2	TCA760	Mullard	Line Audio Amplifier
15IC 1	78H12	Fairchild	12V Regulator
15IC 2	7805KC	Fairchild	5V Regulator
16IC 1	UA723	Fairchild	Voltage Regulator
16IC 2	UA723	Fairchild	Voltage Regulator

LIST OF MAJOR SPARES, POTENTIOMETERS, COILS & INDUCTORS

REF	DESCRIPTION	PART NO.
	MODULES & UNITS:-	
2	440- 800MHz Tuner Unit	D5359
3	800-1000MHz Tuner Unit	D5365
5	Oscillator Divide by 10 Unit	D5378
6	Selectivity Module	D5457
7	FM Module	D5458
8	AM Detector/Video Module	D5461
9	AM/IF Amplifier Module	D5459
10	Crystal Calibrator Unit	D5456
12	AGC Muting Module	D5460
16	Invertor Unit	D5463
	PRINTED CIRCUIT BOARDS (INCLUDING COMPONENTS):-	
2	440- 800MHz Tuner Board	LP3662/1
3	800-1000MHz Tuner Board	LP3662/2
5	Oscillator Divide by 10 Board	LP3662/11
6	Selectivity Unit Board with FL1 fitted	LP3662/10
6	Selectivity Unit Board with optional FL2 fitted	LP3662/14
7	FM Module Board	LP3662/9
8	AM Detector/Video Module Board	LP3662/6
9	AM/IF Amplifier Board	LP3662/7
10	Crystal Calibrator Board	LP3662/12
11	Sync/AFC Amplifier Board	LP3662/5
12	AGC Muting Board	LP3662/8
13	24V Switched Mode Board	LP3662/15
14	3Ω & 600Ω Audio Board	LP3399/27
16	Invertor (PSU) Board	LP3399/2
17	Sync Inverter Board	LP3662/4
	SWITCHES & ASSEMBLIES:-	
S 1	Mains-Bat-Off	10405P
S 2	AM/FM	10406P
S 3	Muting	7352P
S 4	Cal Frequency	9480P
S 5	LS Off/On	7352P
S 6	Meter	8828P
S 7	Sync/AFC	7352P
S 8	Man/AGC	8828P
S 9	Range	10361P
S10	Selectivity	10360P

REF	DESCRIPTION	PART NO.
	TRIMMER CAPACITORS:-	
2C 5	0p2-2p)	
2C11	0p2-2p) Type PTU/2/ST) Part of 440-800MHz	
2C14	0p2-2p) 600V) Tuner Unit	
2C28	0p2-2p)	
3C 6	0p2-2p)	
3C11	0p2-2p) Type PTU/2/ST) Part of 800-1000MHz	
3C13	0p2-2p) 600V) Tuner Unit	
3C37	0p2-2p)	
5C 9	2p5-6p 160V Oscillator Divide by 10	7288P
8C21	7-35p 160V FM Module	7291P
10C2	10-60p 250V Crystal Cal. Unit	7290P
12C17	4p5-20p 160V AGC Muting Module	7567P
	POTENTIOMETERS:-	
1RV 1	10k Preset Linear Carbon METER ZERO	6480P
1RV 2	50k Logarithmic Carbon AF GAIN	9114P
1RV 3	47k Preset Linear Carbon LINE LEVEL	6488P
1RV 4	100k Ten-Turn (Bourns 3500S-2-104) TUNING	9474P
1RV 5	10k FINE TUNE	8620P
1RV 6	1k Linear Carbon IF GAIN) Concentric	9104P
1RV 7	50k Linear Carbon RF GAIN)	
1RV 8	10k Preset Linear Carbon MUTING LEVEL	6480P
1RV 9	10k Preset AFC/SYNC BALANCE	10407P
1RV10	10k Preset AFC/SYNC BALANCE	10407P
2RV 1	470k Preset TUNING VOLTAGE ADJUST	9483P
2RV 2	470k Preset TUNING VOLTAGE ADJUST	9483P
2RV 3	470k Preset TUNING VOLTAGE ADJUST	9483P
2RV 4	470k Preset TUNING VOLTAGE ADJUST	9483P
3RV 1	470k Preset TUNING VOLTAGE ADJUST	9483P
3RV 2	470k Preset TUNING VOLTAGE ADJUST	9483P
3RV 3	470k Preset TUNING VOLTAGE ADJUST	9483P
3RV 4	470k Preset TUNING VOLTAGE ADJUST	
4RV	REFER TO SYNCHRONISER MANUAL	
8RV 1	470k Preset Linear Carbon FM VIDEO OUTPUT LEVEL	9486P
8RV 2	470k Preset Linear Carbon AM VIDEO OUTPUT LEVEL	9486P

REF	DESCRIPTION	PART NO.
	POTENTIOMETERS continued.....	
11RV 1	100k Preset Linear Carbon SET AFC LEVEL	10413P
12RV 1	47k Preset Linear Carbon SET IF AGC DC LEVEL	9489P
13RV 1	470k Preset Linear Carbon SET +24V	10414P
	COILS:-	
2L 1	IF Rejection Coil	D5357
2L 2	Collector Coil	D5358
2L 3	Drain Coil	D5358
2L 4	Tuned Line	10323P
2L 5	Link Part of 2C6 470p	-
2L 6	Tuned Line	10323P
2L 7	Link	10324P
2L 8	Link	10325P
2L 9	Tuned Line	10419P
2L10	Link	10326P
2L11	Splitter Coil	D5356
2L12	Splitter Coil	D5355
2L13	Tuned Line Oscillator	10327P
3L 1	IF Rejection Coil	D5357
3L 2	Collector Coil	D5358
3L 3	Drain Coil	D5358
3L 4	Tuned Line	10331P
3L 5	Tuned Line	10331P
3L 6	Link	10332P
3L 7	Link	10333P
3L 8	Tuned Line	10420P
3L 9	Link	10334P
3L10	Splitter Coil	D5356
3L11	Splitter Coil	D5360
3L12	Tuned Line Oscillator	10330P
6L 1	Drain Coil	D5343
6L 2)		D5336
6L 3)		D5337
6L 4)		D5337
6L 5)	LC Filter Coils	D5339
6L 6)		D5340
6L 7)		D5340
6L 8)		D5342
7L 1	FM Input Coil	D5351

REF	DESCRIPTION	PART NO.	
	COILS continued....		
7L 2	FM Oscillator Coil	D5352	
7L 3	FM Interstage Coil	D4786	
7L 4	FM Interstage Coil	D4785	
7L 5	FM Discriminator Coil	D4787	
	CHOKES:-		
2CH 1	0.47 μ H	EDDYSTONE	D5355
2CH 2	0.47 μ H	EDDYSTONE	D5355
2CH 3	10mH SC60	SIGMA	9379P
2CH 4	10 μ H SC60	SIGMA	9384P
2CH 5	47 μ H SC60	SIGMA	9492P
2CH 6	47 μ H SC60	SIGMA	9492P
3CH 1	0.44 μ H	EDDYSTONE	D5360
3CH 2	0.44 μ H	EDDYSTONE	D5360
3CH 3	10mH SC60	SIGMA	9379P
3CH 4	0.19 μ H	EDDYSTONE	D5361
3CH 5	47 μ H SC60	SIGMA	9492P
3CH 6	47 μ H SC60	SIGMA	9492P
5CH 1	6.7 μ H	EDDYSTONE	D4919
5CH 2	-	EDDYSTONE	D2854
6CH 1	3.2 μ H	EDDYSTONE	D4782
6CH 2	3.2 μ H	EDDYSTONE	D4782
6CH 3	3.2 μ H	EDDYSTONE	D4782
6CH 4	3.2 μ H	EDDYSTONE	D4782
6CH 5	3.2 μ H	EDDYSTONE	D4782
6CH 6	3.2 μ H	EDDYSTONE	D4782
6CH 7	3.2 μ H	EDDYSTONE	D4782
6CH 8	3.2 μ H	EDDYSTONE	D4782
6CH 9	3.2 μ H	EDDYSTONE	D4782
6CH10	3.2 μ H	EDDYSTONE	D4782
6CH11	3.2 μ H	EDDYSTONE	D4782
6CH12	3.2 μ H	EDDYSTONE	D4782
6CH13	3.2 μ H	EDDYSTONE	D4782
6CH14	3.2 μ H	EDDYSTONE	D4782
7CH 1	3.2 μ H	EDDYSTONE	D4782
7CH 2	3.2 μ H	EDDYSTONE	D4782
7CH 3	3.2 μ H	EDDYSTONE	D4782
7CH 4	3.2 μ H	EDDYSTONE	D4782
7CH 5	10 μ H SC60	SIGMA	9384P
7CH 6	3.2 μ H	EDDYSTONE	D4782

REF	DESCRIPTION	PART NO.
	CHOKES continued.....	
8CH 1	3.2 μ H EDDYSTONE	D4782
8CH 2	3.2 μ H EDDYSTONE	D4782
8CH 3	3.2 μ H EDDYSTONE	D4782
8CH 4	3.2 μ H EDDYSTONE	D4782
8CH 5	FERRITE BEAD FX1115 MULLARD	10415P
8CH 6	FERRITE BEAD FX1115 MULLARD	10415P
8CH 7	3.2 μ H EDDYSTONE	D4782
8CH 8	FERRITE BEAD FX1115 MULLARD	10415P
8CH 9	FERRITE BEAD FX1115 MULLARD	10415P
9CH 1	3.2 μ H EDDYSTONE	D4782
9CH 2	3.2 μ H EDDYSTONE	D4782
9CH 3	3.2 μ H EDDYSTONE	D4782
9CH 4	3.2 μ H EDDYSTONE	D4782
9CH 5	3.2 μ H EDDYSTONE	D4782
9CH 6	3.2 μ H EDDYSTONE	D4782
9CH 7	3.2 μ H EDDYSTONE	D4782
12CH 1	3.2 μ H EDDYSTONE	D4782
12CH 2	3.2 μ H EDDYSTONE	D4782
12CH 3	3.2 μ H EDDYSTONE	D4782
15CH 1	3.2 μ H EDDYSTONE	D4782
15CH 2	3.2 μ H EDDYSTONE	D4782
15CH 3	3.2 μ H EDDYSTONE	D4782
15CH 4	470 μ H SC60 SIGMA	10416P
	TRANSFORMERS:-	
1T 1	Mains	10344P
6T 1	Selectivity Unit EDDYSTONE	D5335
8T 1	AM IF Transformer EDDYSTONE	D5348
12T1	Muting	D5350
12R2	AGC Amplifier	D5349
	CRYSTALS:-	
6XL 1	"FL2" Option	10336P
7XL 1	57.9MHz Style "J" Series Rex. \pm .002% 25 $^{\circ}$ C	10337P
10XL1	50MHz \pm .005% Style "J" QC 894	10417P

REF	DESCRIPTION	PART NO.	
	FILTERS:-		
6FL 1	Acoustic Wave Filter SW102M	10418P	
	PLUGS & SOCKETS:-		
SK1	DC Supply	3 Way	8855P
SK2	Frequency Synchroniser	Min. Co. Ax	7292P
PL2	Frequency Synchroniser	Min. Co. Ax Plug	7293P
SK3	Frequency Synchroniser	Min. Co. Ax Socket	7292P
PL3	Frequency Synchroniser	Min. Co. Ax	7293P
SK4	FM Output	BNC	7725P
SK5	Voltage Inverter Unit	6 Way	6082P
PL5	Voltage Inverter Unit	6 Way	6081P
SK6	Oscillator Output	15 Way	7770P
PL6	Oscillator Output	15 Way	7772P
SK7	Oscillator Output to divide by 10	Min. Co. Ax	7292P
PL7	Oscillator Output to divide by 10	Min. Co. Ax	7293P
SK8	Oscillator Output to divide by 10	Min. Co. Ax	7292P
PL8	Oscillator Output to divide by 10	Min. Co. Ax	7293P
SK9	Aerial Input 2	BNC	7225P
SK10	Aerial Input 1	BNC	7225P
SK11	Selectivity Unit	Min. Co. Ax Socket	10421P
PL11	IF Output to Filter Unit	Min. Co. Ax	7293P
SK12	Selectivity Unit	Min. Co. Ax	7292P
PL12	Selectivity Unit	Min. Co. Ax	7293P
SK13	Selectivity Unit	Min. Co. Ax	7292P
PL13	Selectivity Unit	Min. Co. Ax	7293P
SK14	FM Unit	Min. Co. Ax	7292P
PL14	FM Unit	Min. Co. Ax	7293P
SK15	AM Unit	Min. Co. Ax	7292P
PL15	AM Unit	Min. Co. Ax	7293P
SK16	Oscillator Output to divide by 10	Min. Co. Ax	7292P
PL16	Oscillator Output to divide by 10	Min. Co. Ax	7293P
SK17	Oscillator Output to divide by 10	Min. Co. Ax	7292P
PL17	Oscillator Output to divide by 10	Min. Co. Ax	7293P
SK18	50MHz	BNC	7225P
SK19	RF Oscillator Output	BNC	7225P

REF	DESCRIPTION	PART NO.
	PLUGS & SOCKETS continued.....	
SK20	AM Detector and Video Amp)	
	Positive)	
SK21	AM Detector and Video Amp) BNC	7225P
	Negative)	
SKA	Ancillaries 15 Way	7770P
SK22	IF Output High Level BNC	7225P
SK23	IF Output Low Level BNC	7225P
	Phones Output Socket	8736P
	Phones Plug	6567P
PLA	Ancillaries Plug 15 Way (with cover)	7771P
	KNOBS:-	
	RF Gain) Dual Concentric	LP3561/1
	IF Gain)	
	Fine Tune	LP3559
	Selectivity	LP3559
	AF Gain	LP3559
	Tune	LP3558
	Range	LP3559
	RELAYS:-	
8RLA	Thorn RH12	8445P
8RLB	Thorn RH12	8445P
8RLC	Thorn RH12	8445P
	MISCELLANEOUS:-	
FS1-3	Fuseholder	8458P
	Earth Terminal	6371P
	Top Cover	9109P
	Bottom Cover	D5377
	Loudspeaker 2" x 3" 8Ω	8657P
	Loudspeaker Fret	8651P
	Meter 50-0-50μA	9019P
	Fuse 1A (Time-lag) 100/1300V AC	9816P
	Fuse 0.5A (Time-lag) 200/2600V AC	9714P
	Fuse 5 AMP DC	7814P
	Lamp 12V 1 Watt Wire-ended	8448P
	Box Sparker	9057P

REF	DESCRIPTION	PART NO.
	MISCELLANEOUS continued..... Spring Extractor (for module covers) Trimming Tool Trimming Tool TT1 Cabinet Assembly	9284P 8333P 8451P LP3481

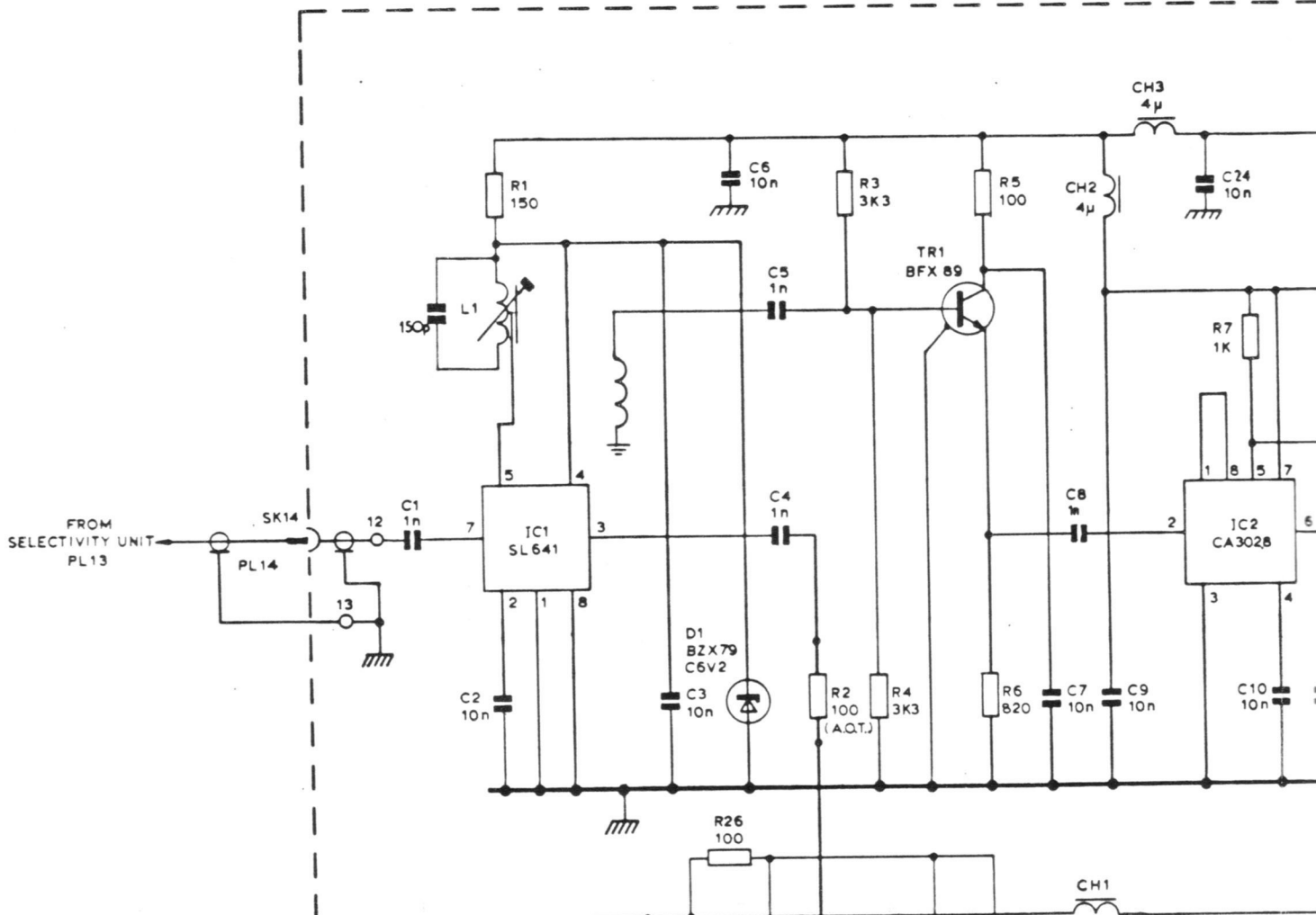
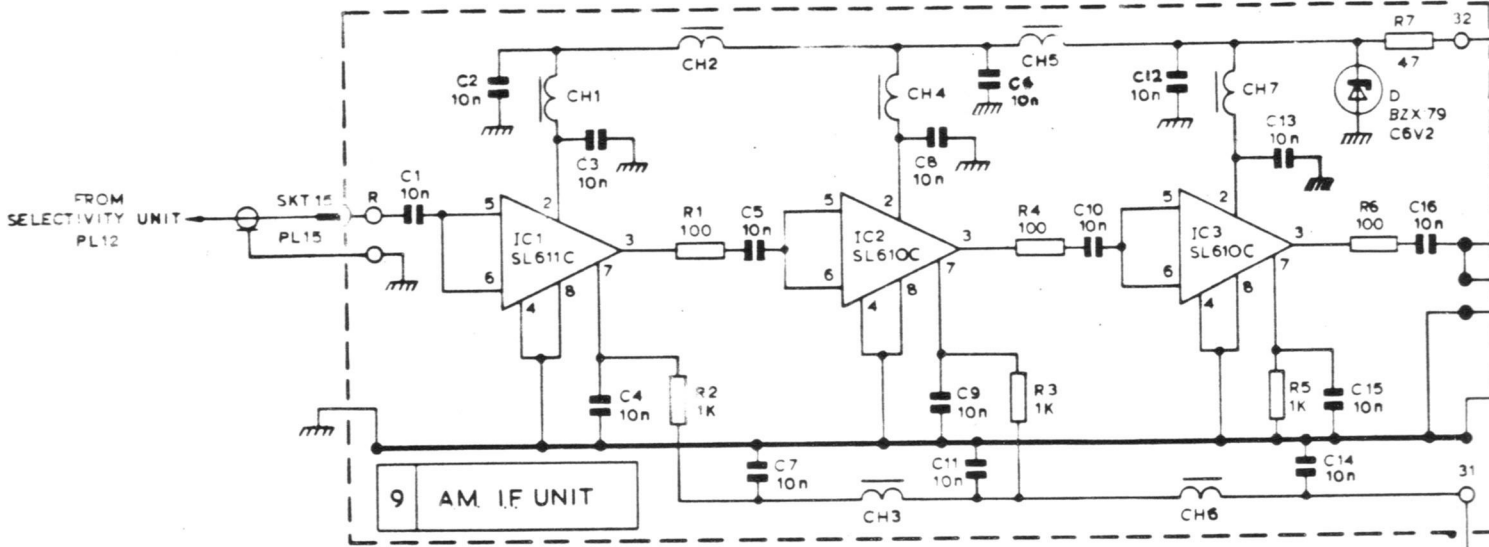

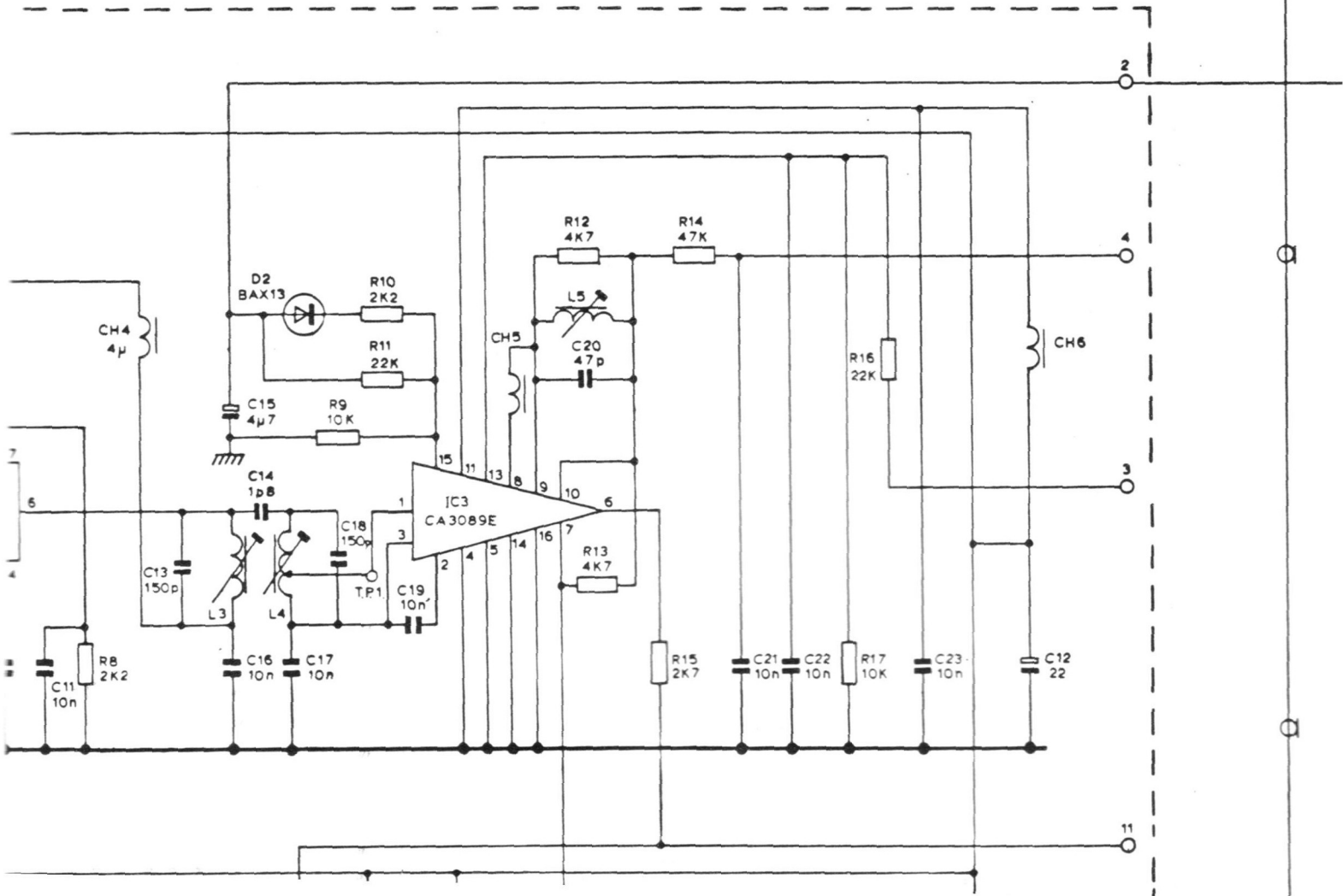
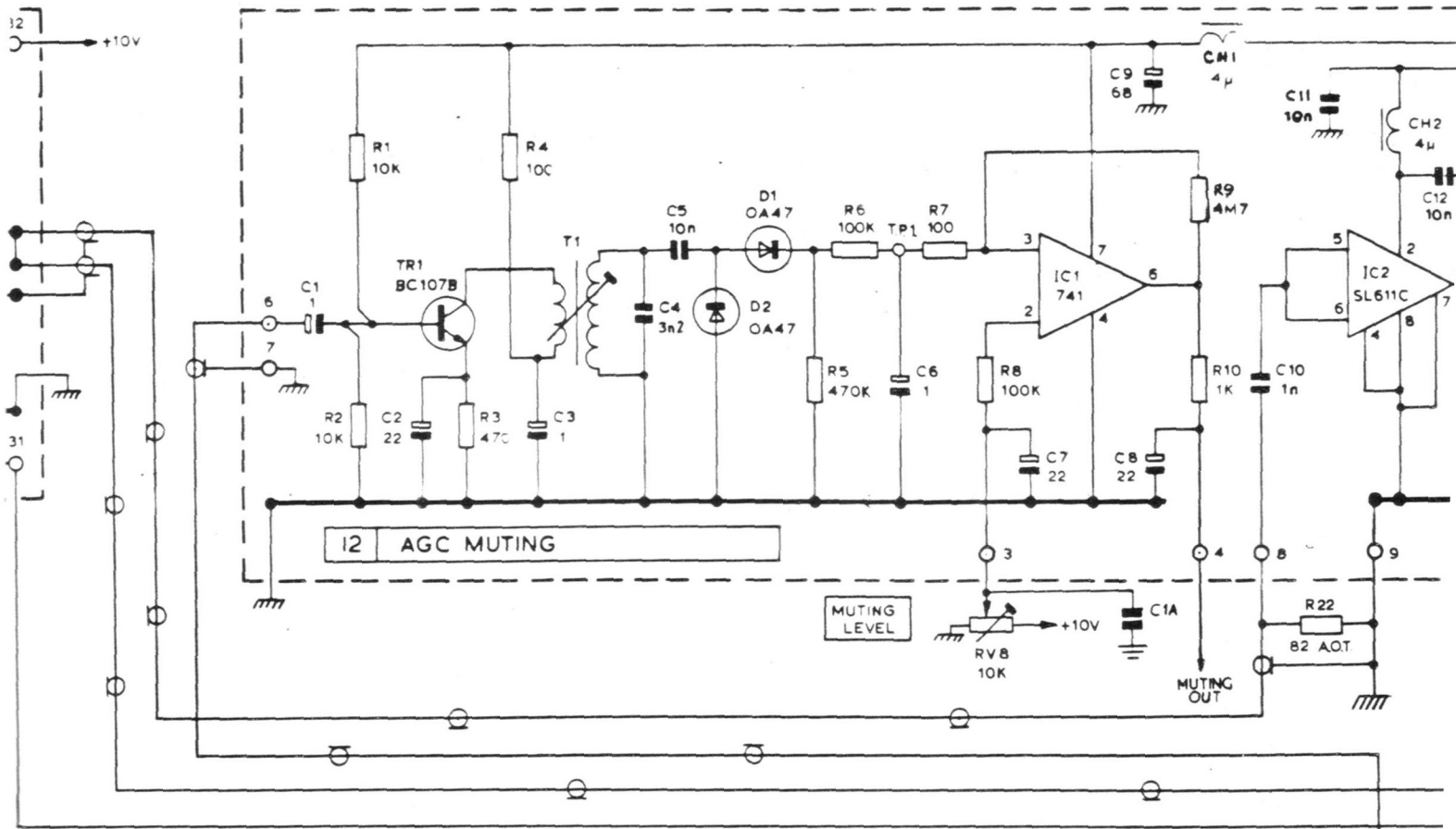

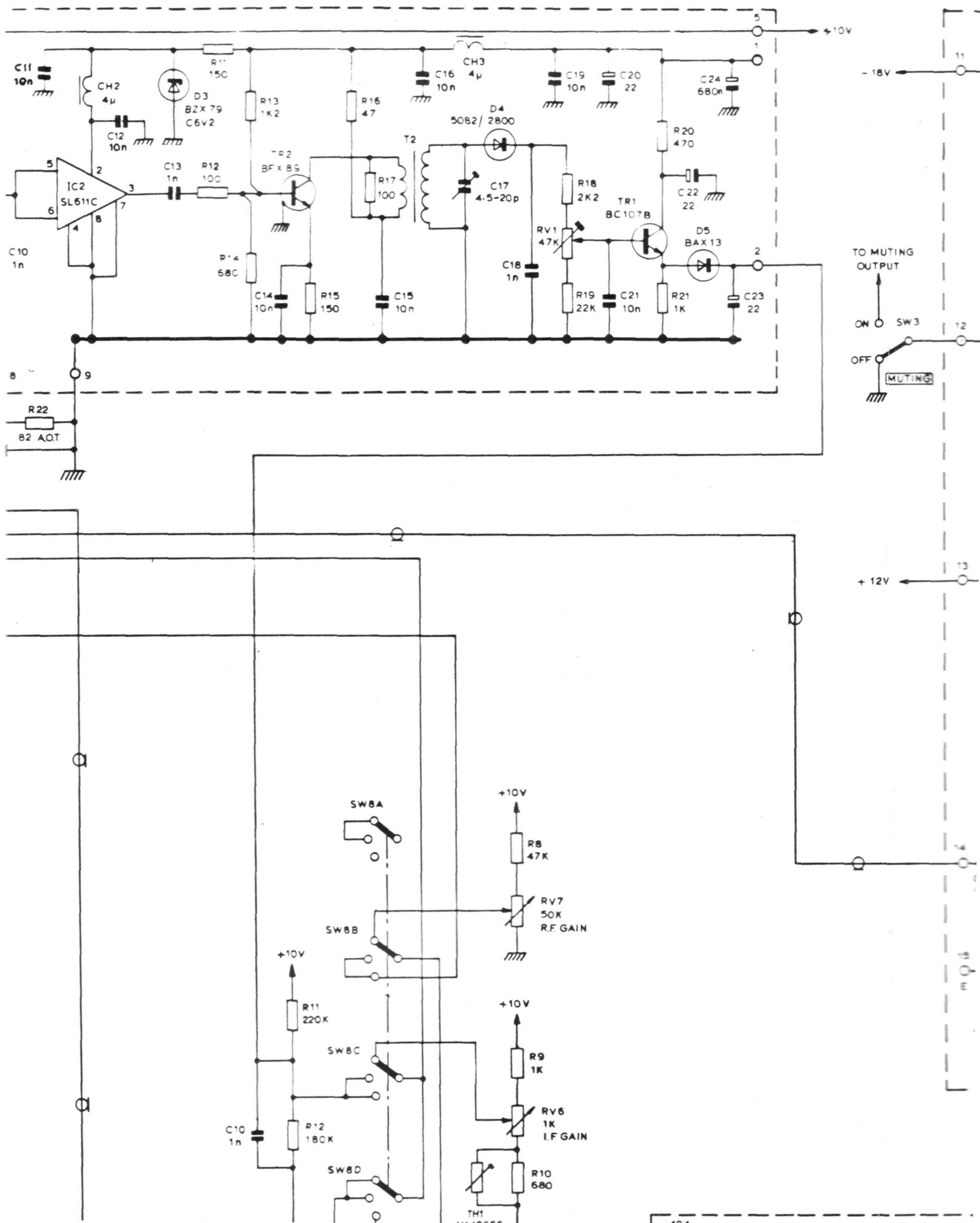

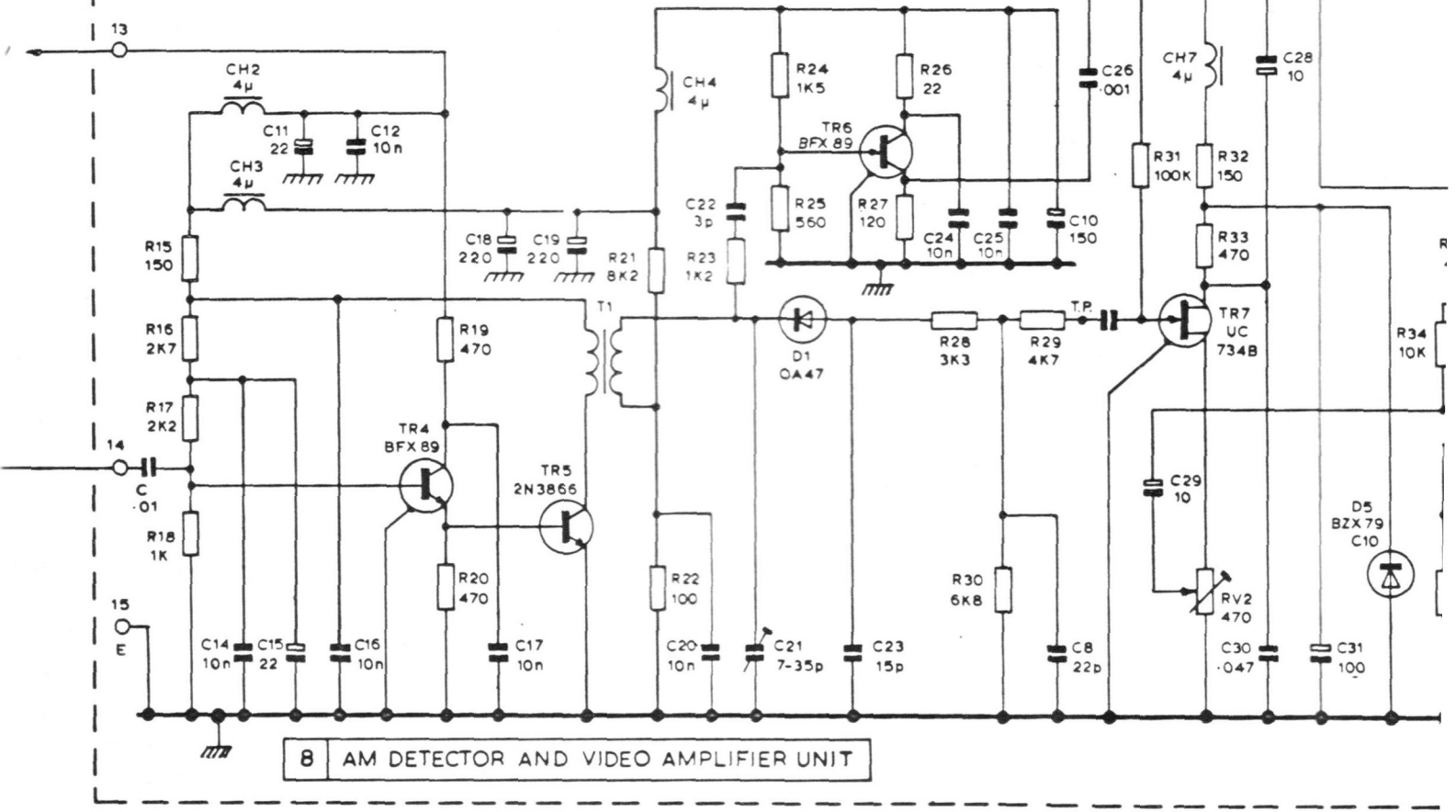
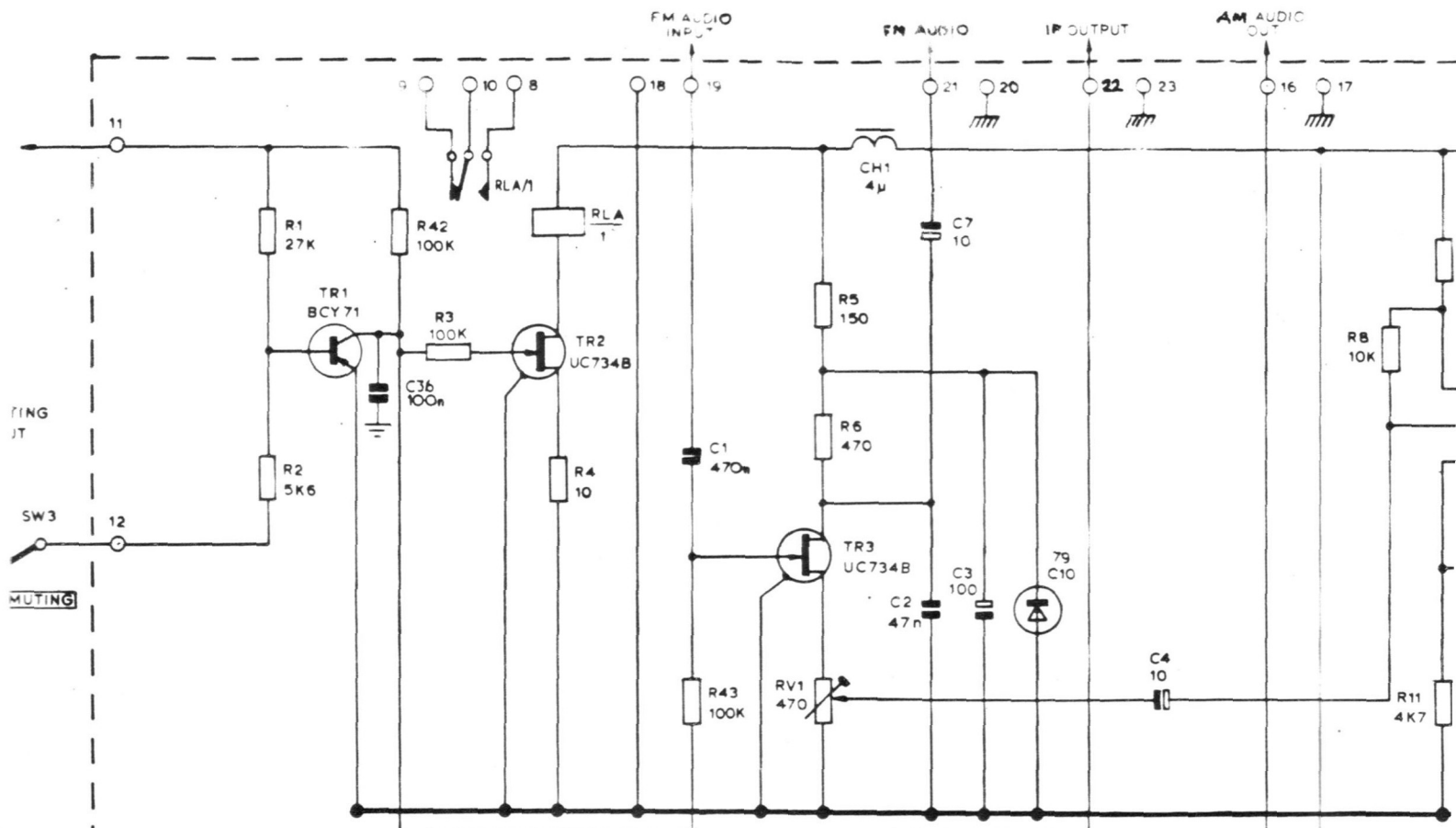

8 AM DETECTOR AND VIDEO AMPLIFIER UNIT

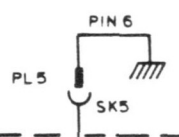

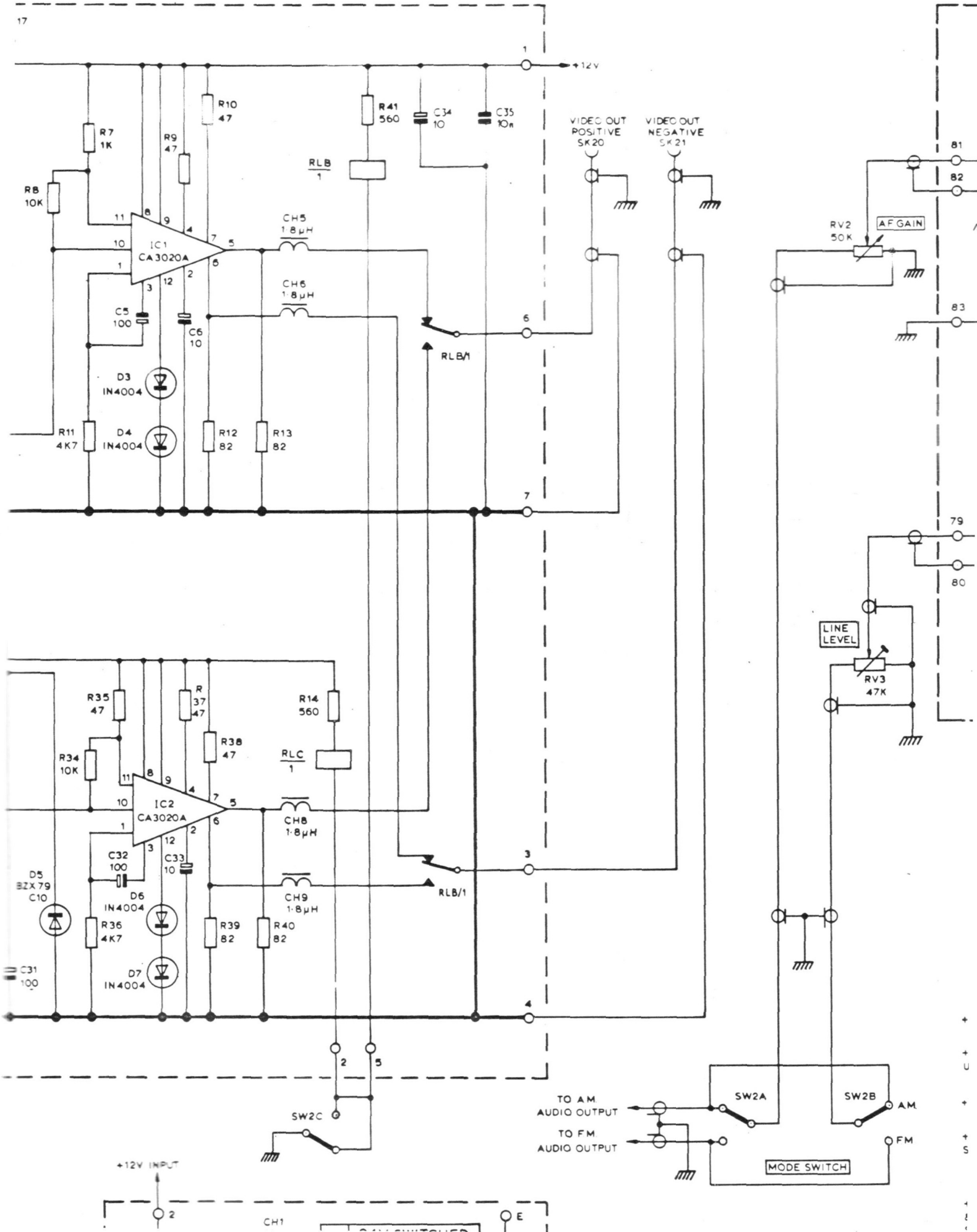

+12V INPUT

TO AM AUDIO OUTPUT
TO FM AUDIO OUTPUT

SW2A SW2B AM FM
MODE SWITCH

LINE LEVEL

RV2 50K AF GAIN

VIDEO OUT POSITIVE SK20
VIDEO OUT NEGATIVE SK21

RLB/1

RLB/1

RLB/1

SW2C

CH1

E

+
+ U
+
+ S
+
+ !
+ !

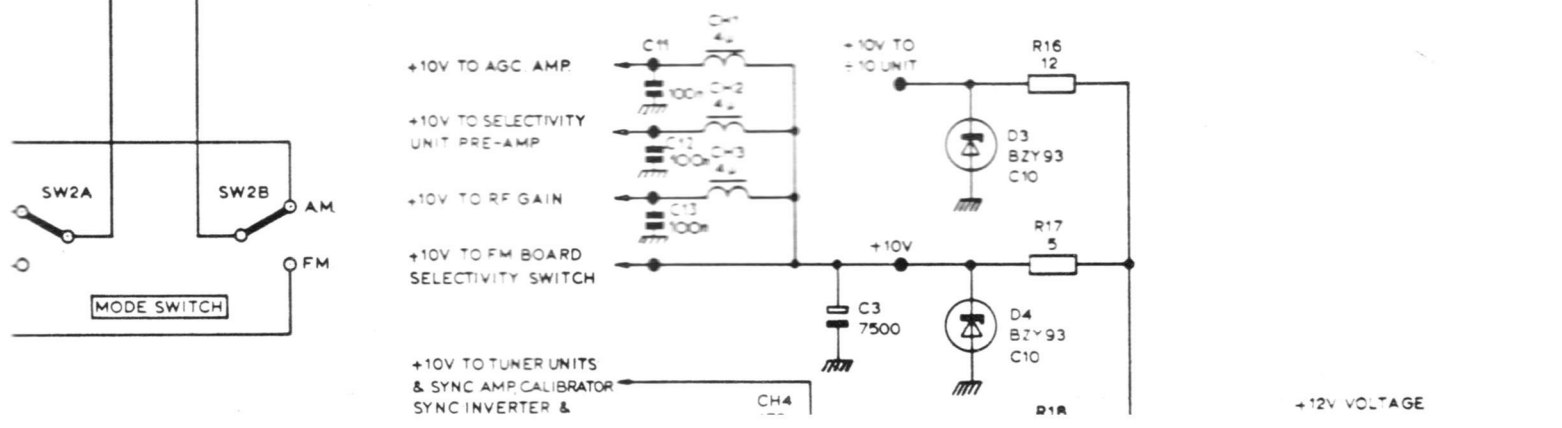
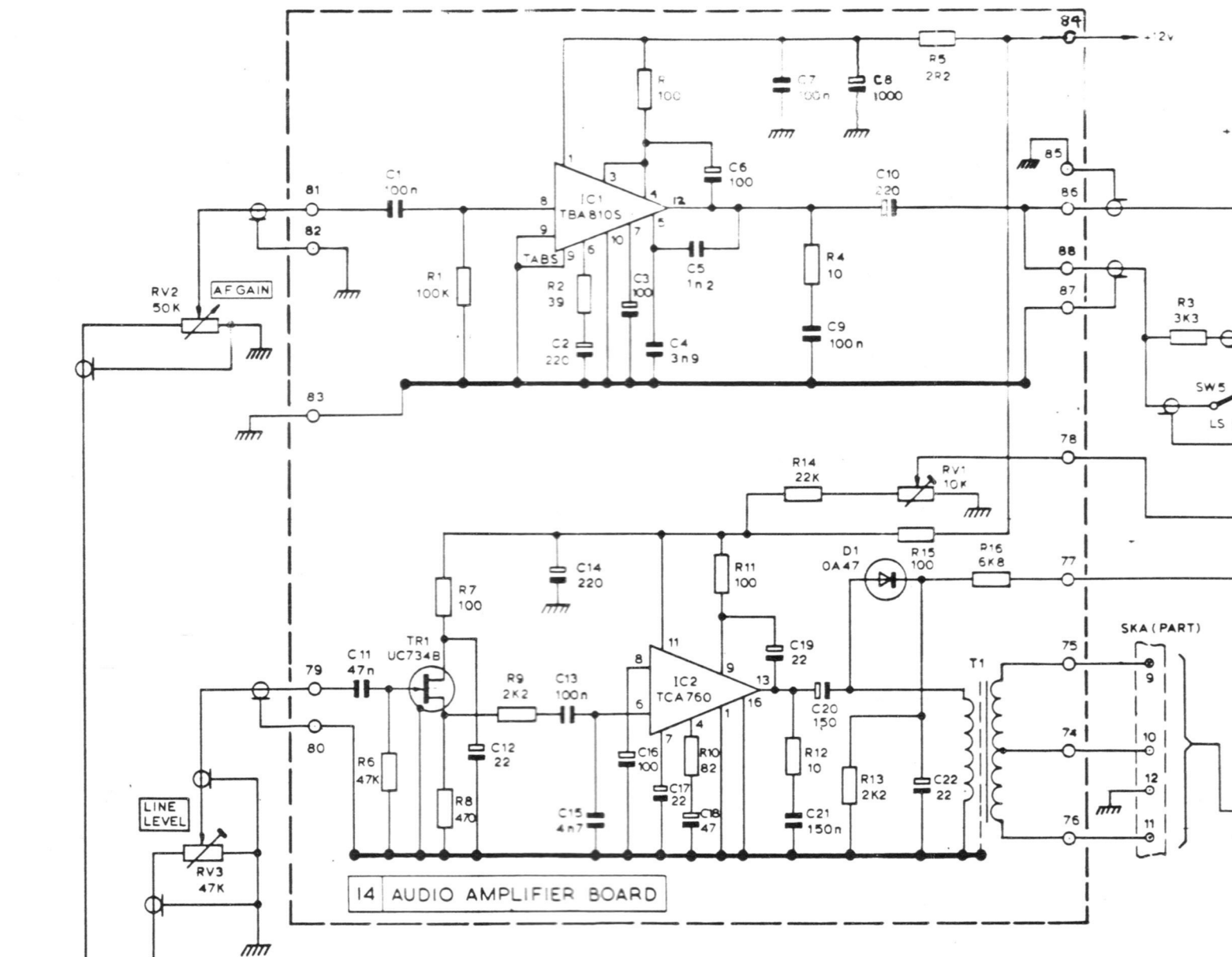

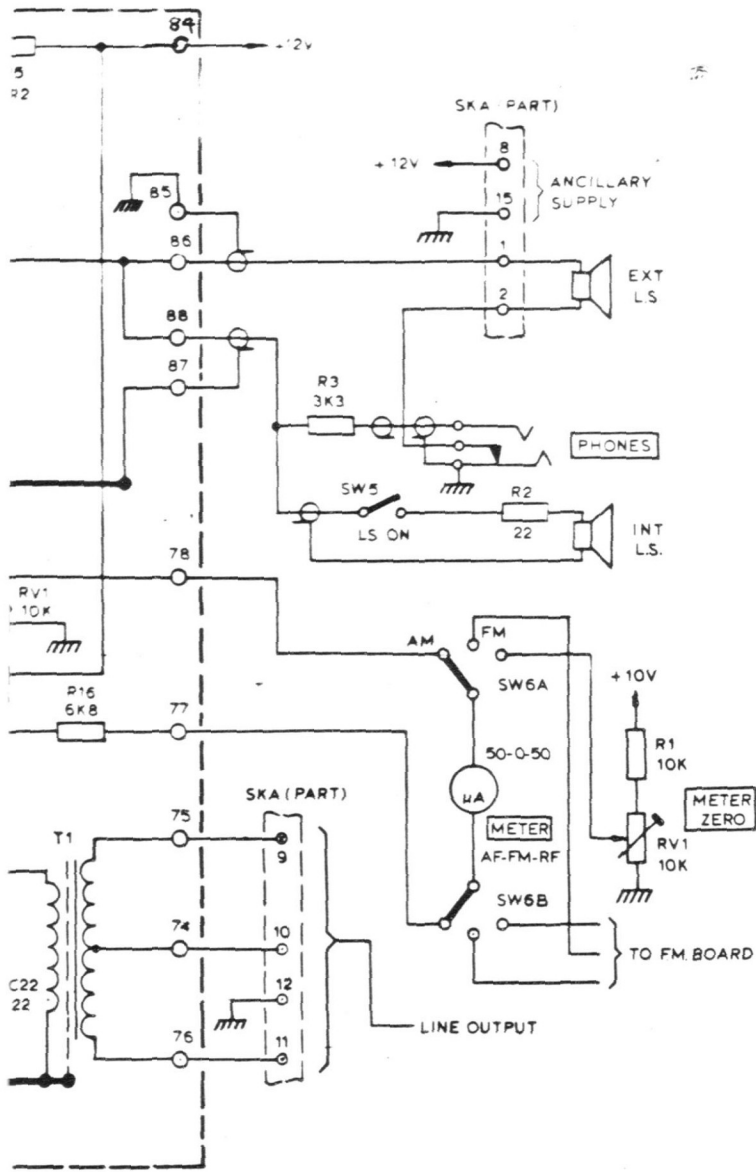

+12V VOLTAGE
REGULATOR

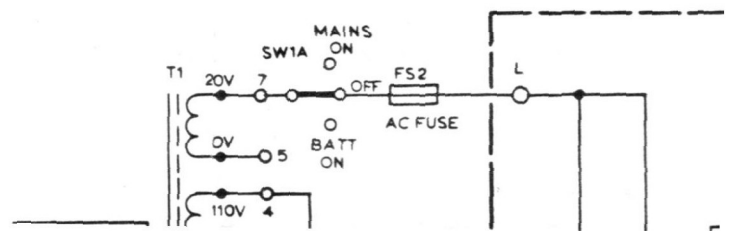

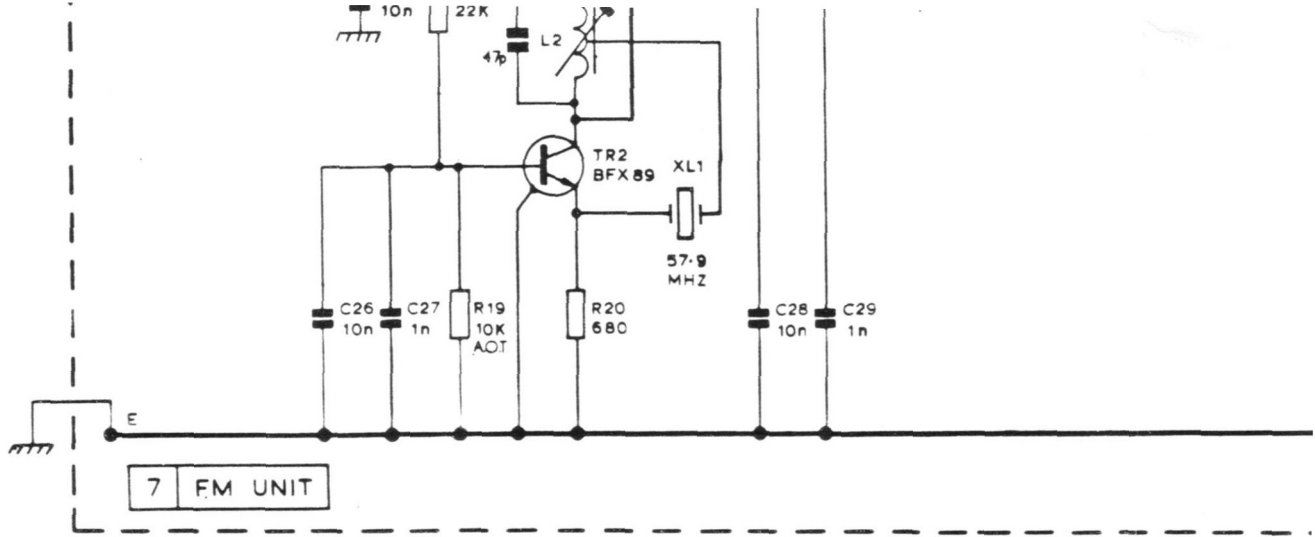

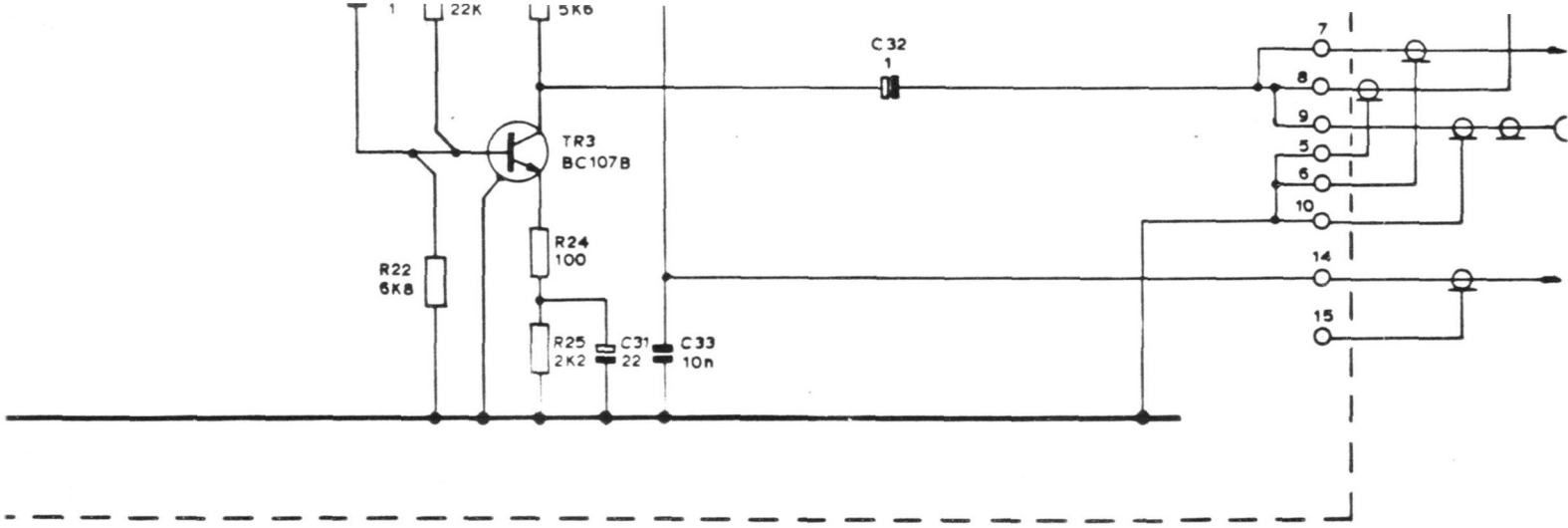

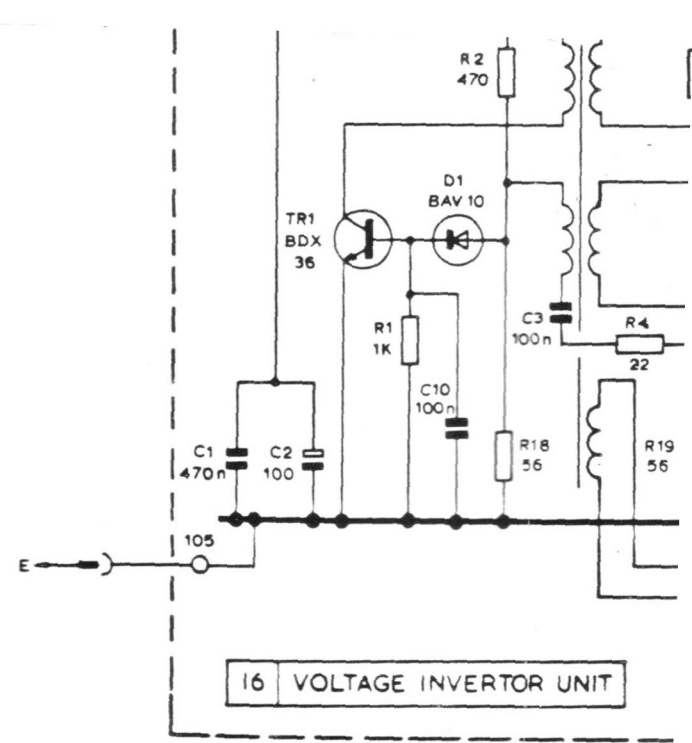
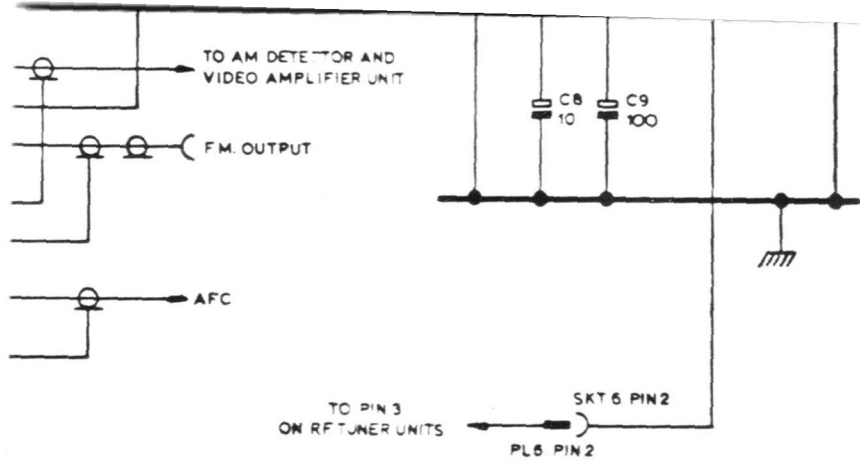

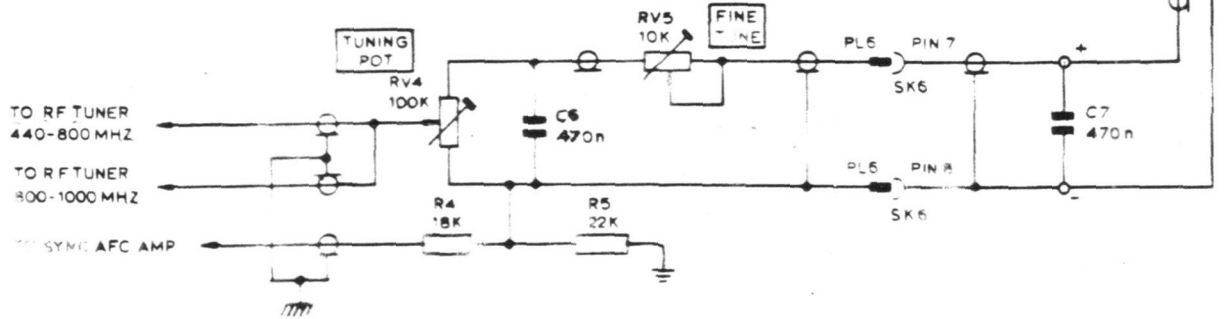
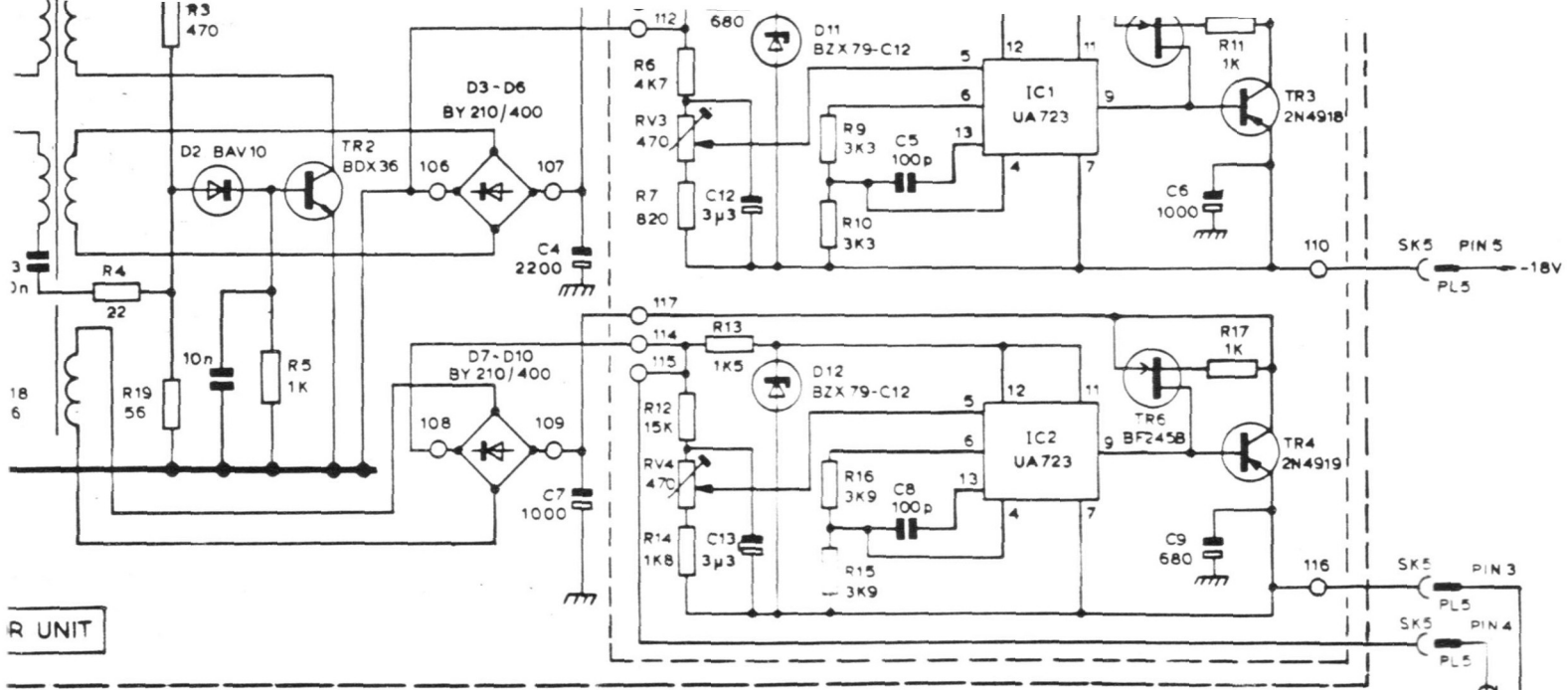

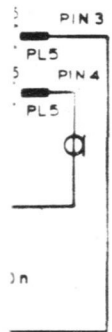
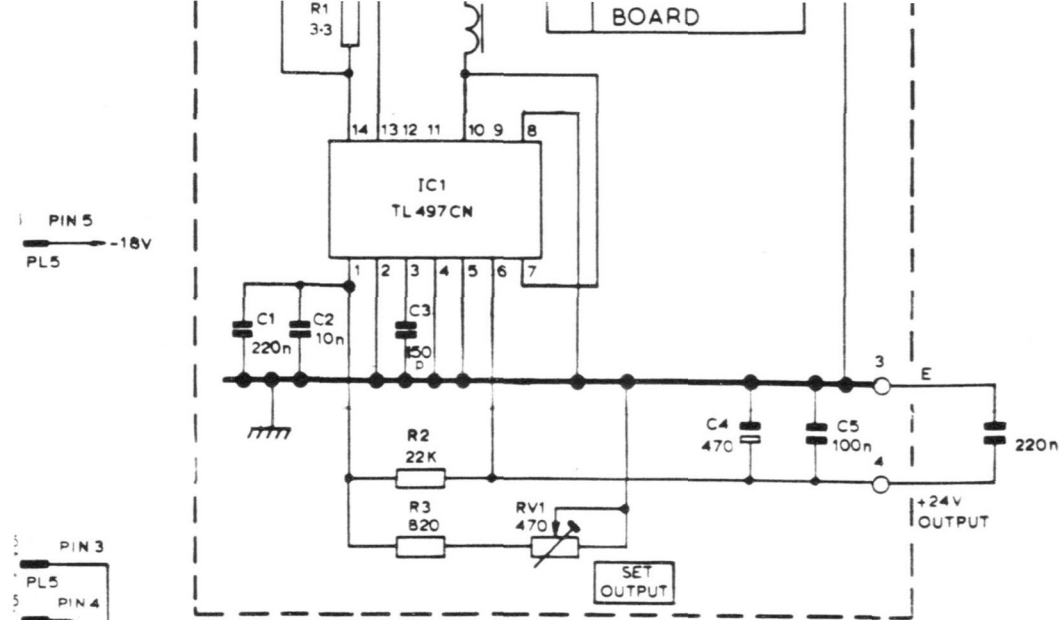

+10V TO MUTING BOARD & IF AMP

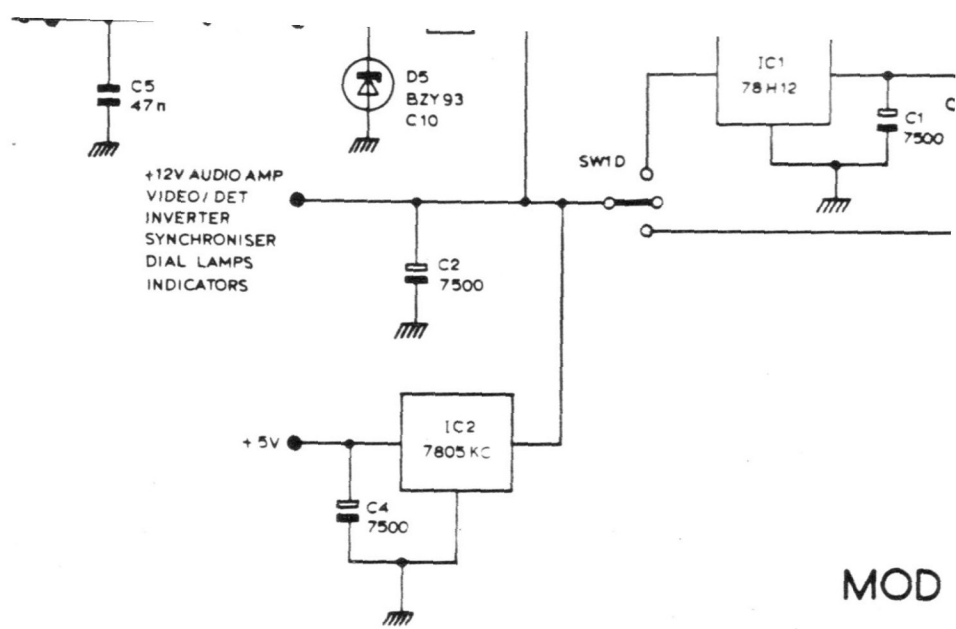

MOD

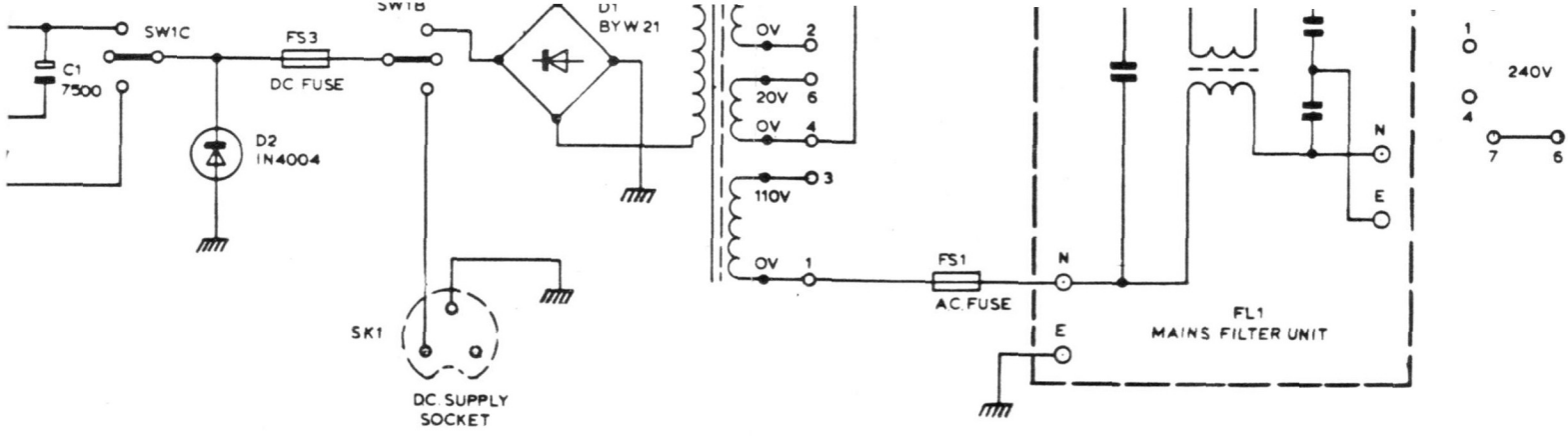

MODEL 1990S PART 1
 BP1451
 ISSUE 1

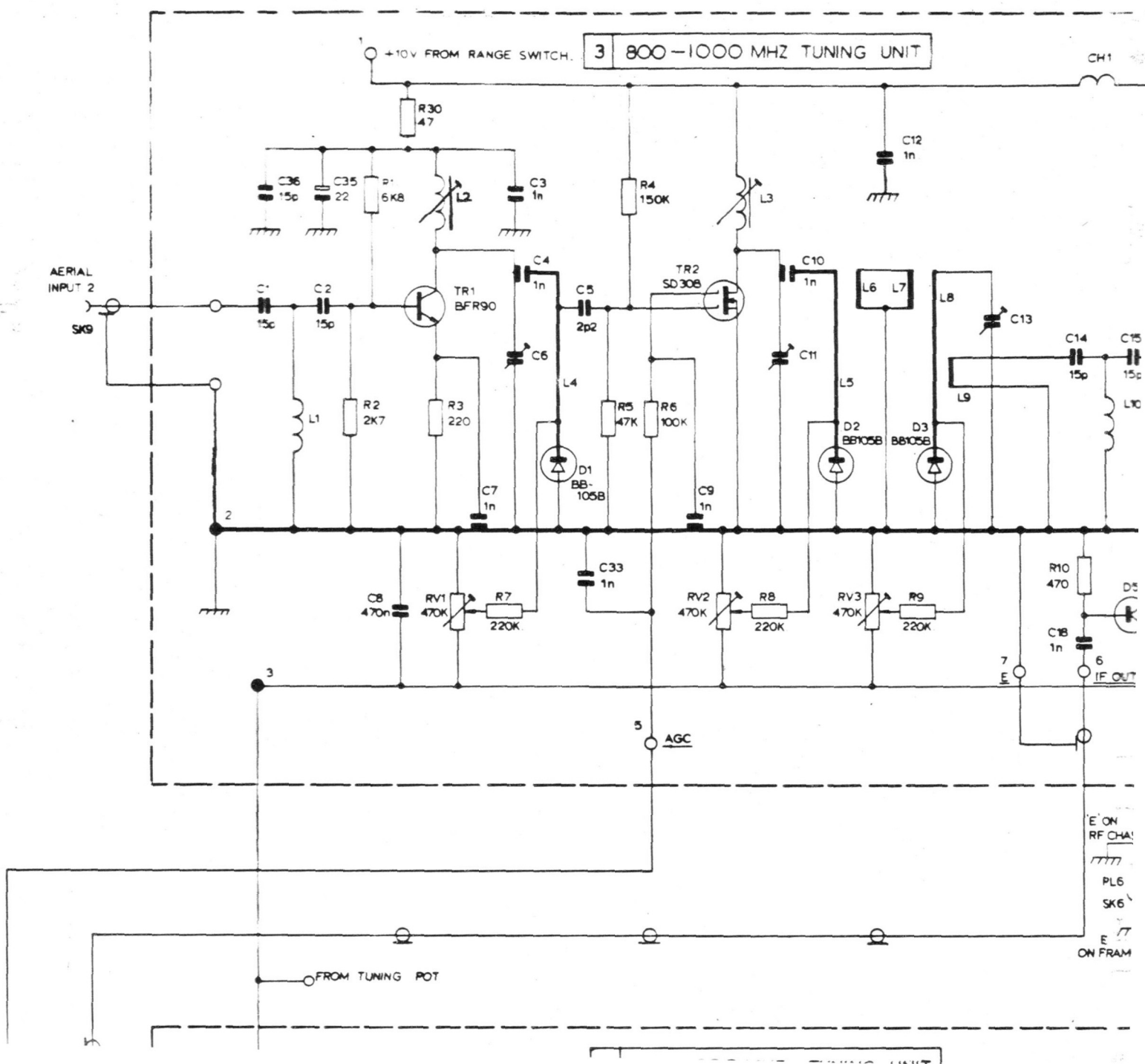

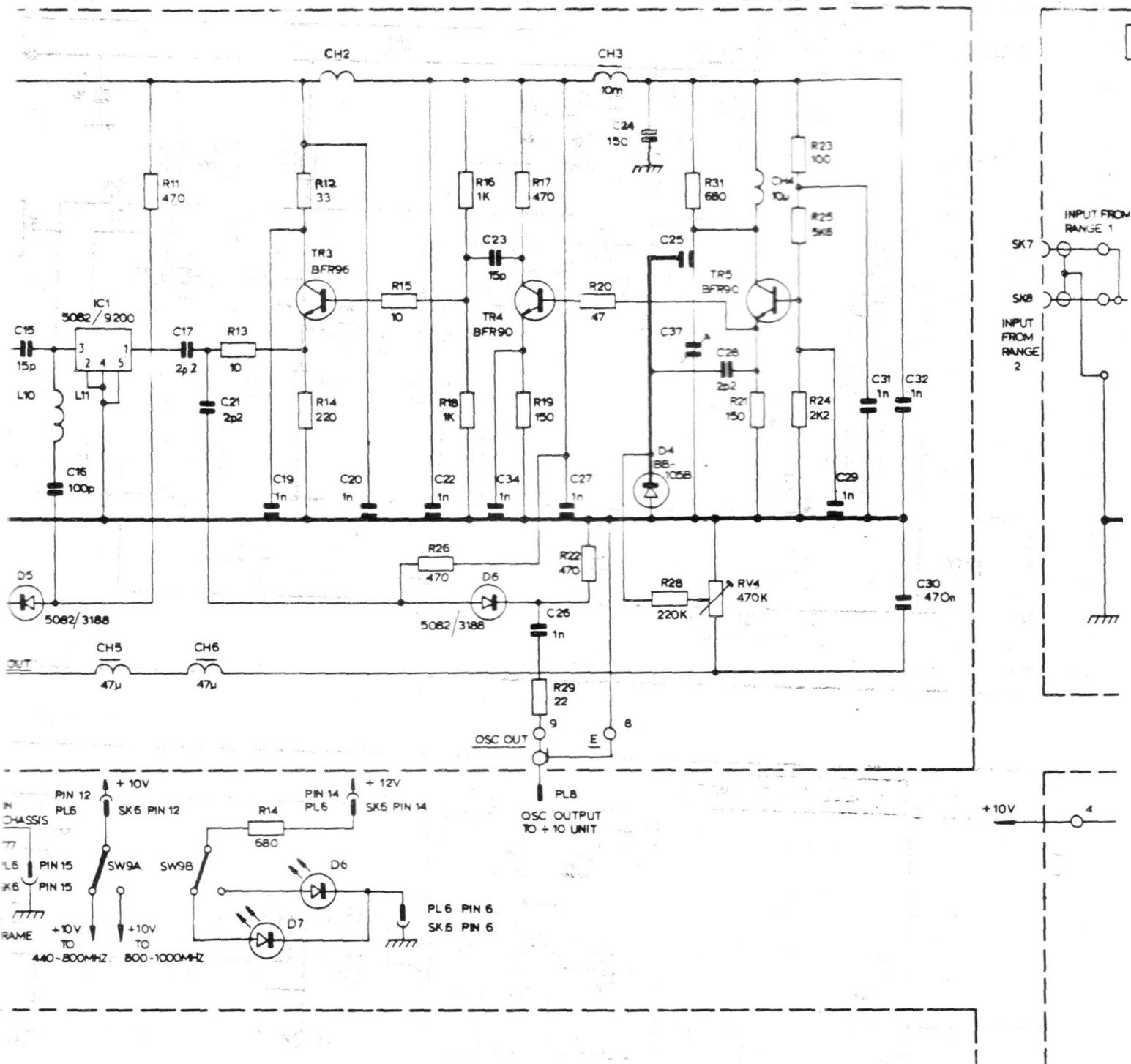

5 OSC OUTPUT ÷ 10 UNIT

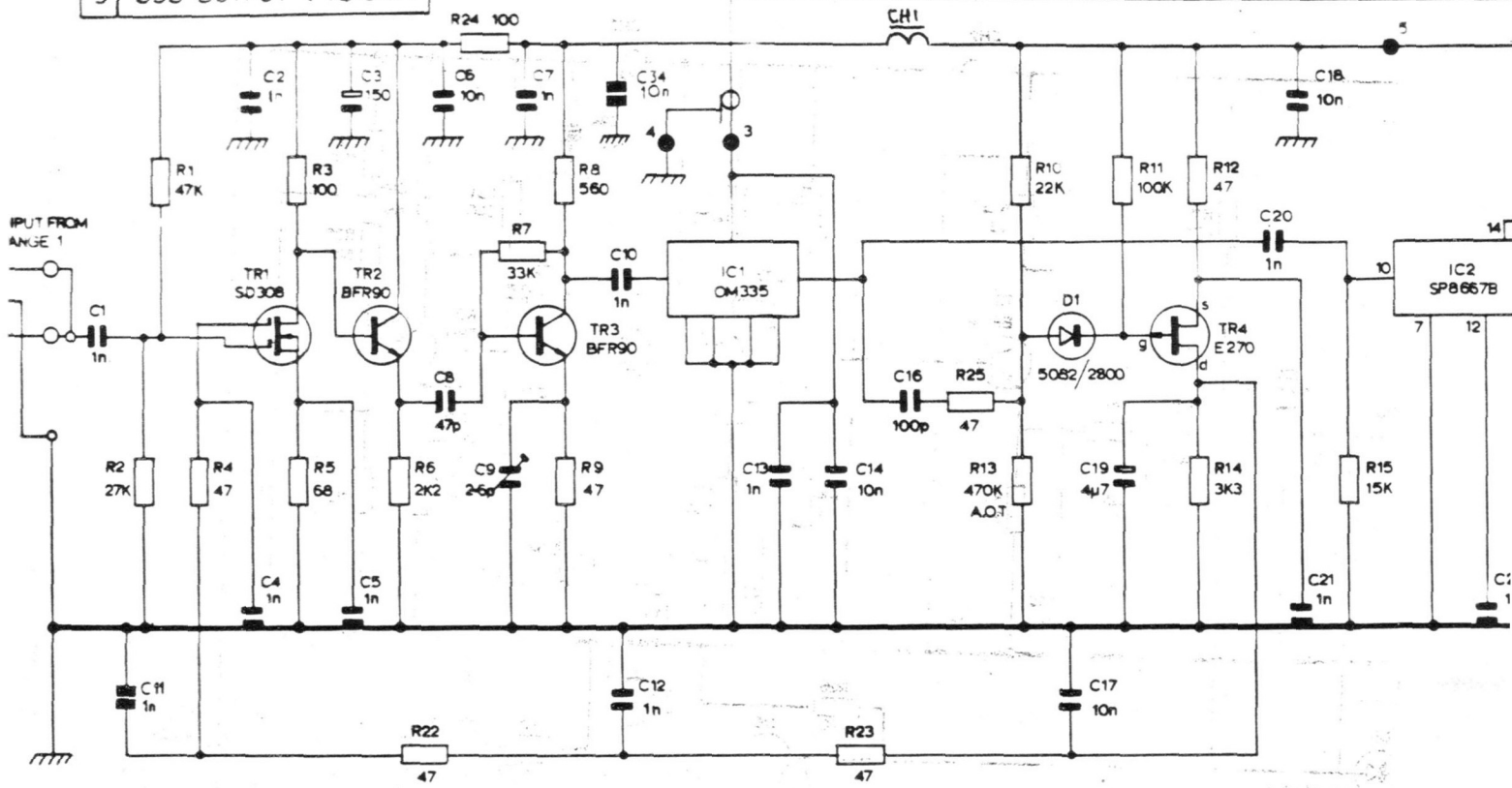

6 SELECTIVITY UNIT

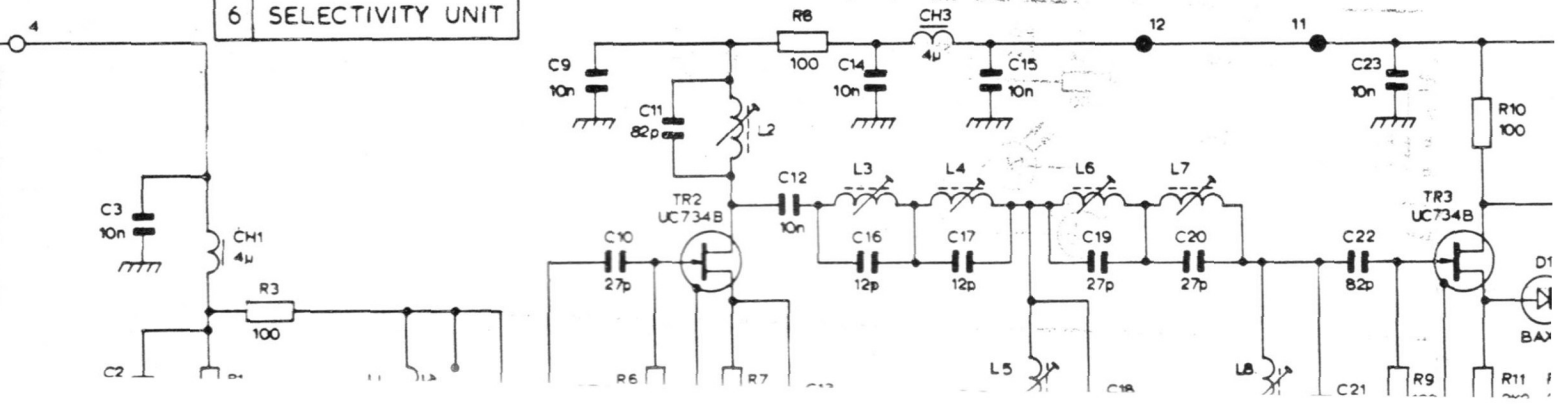

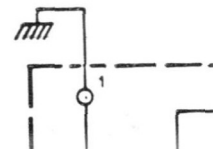
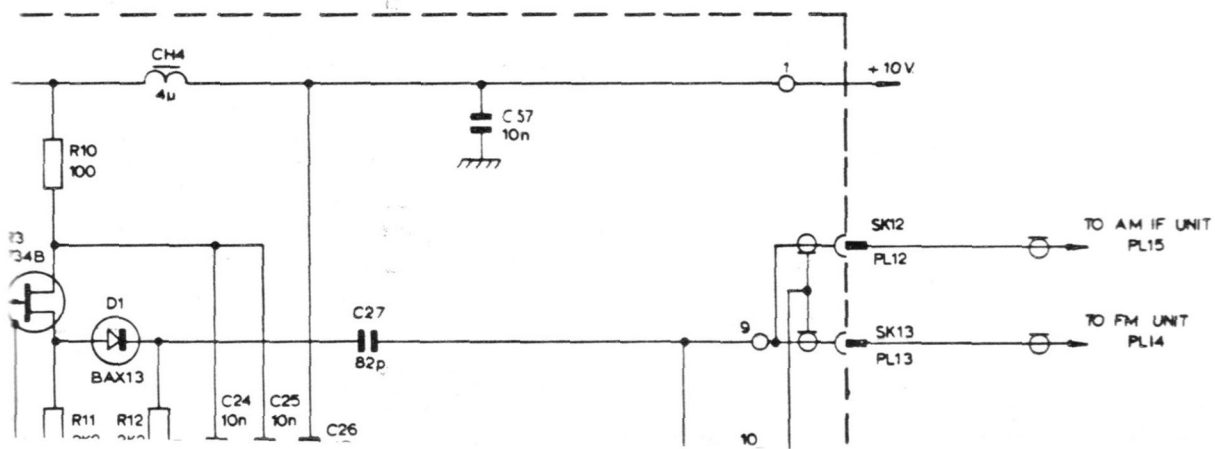
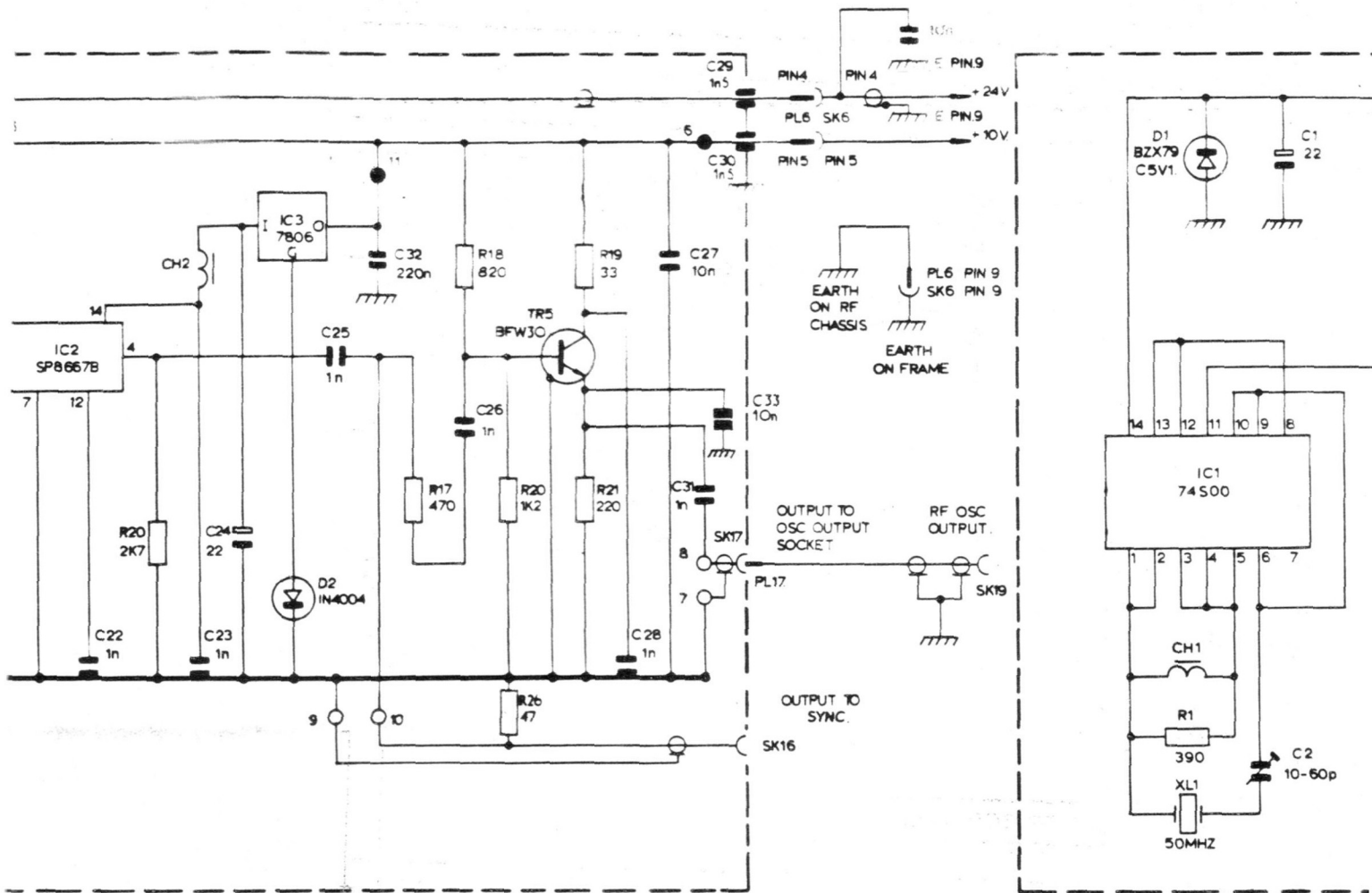

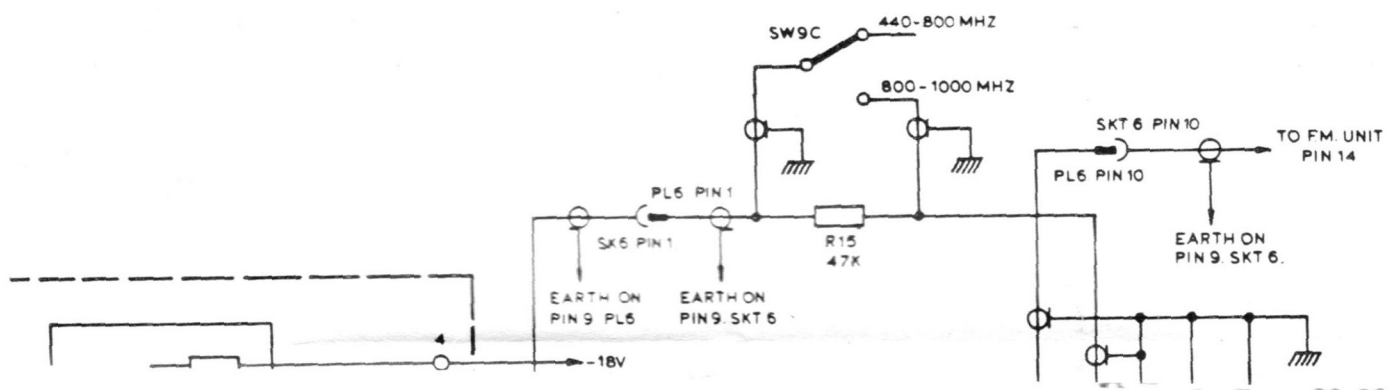
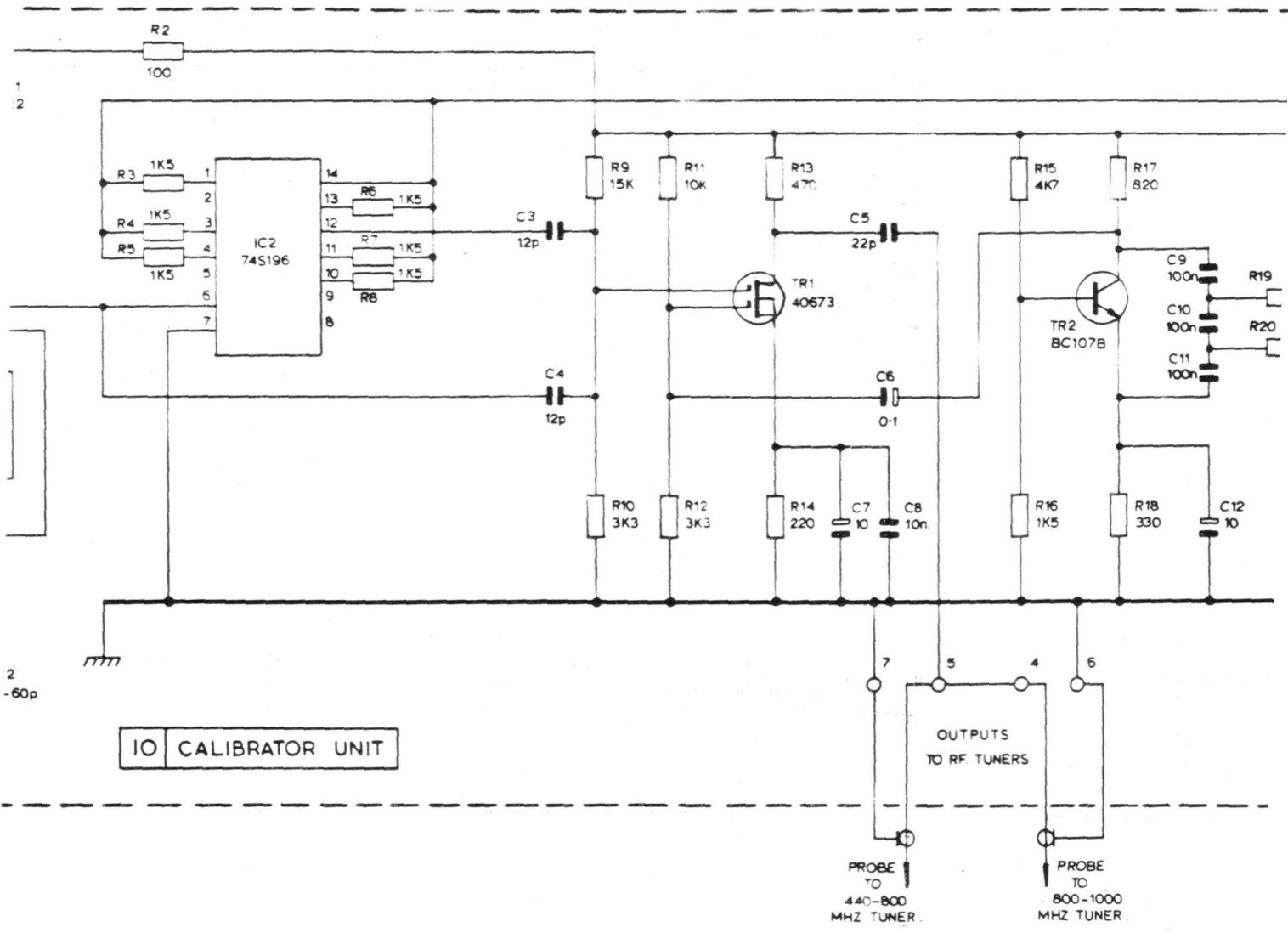

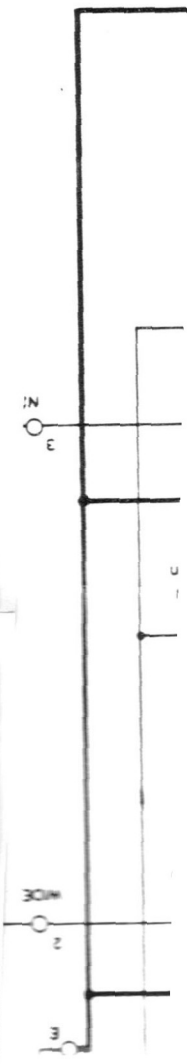
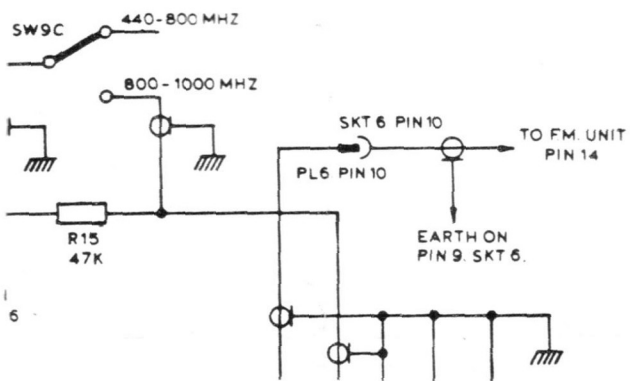
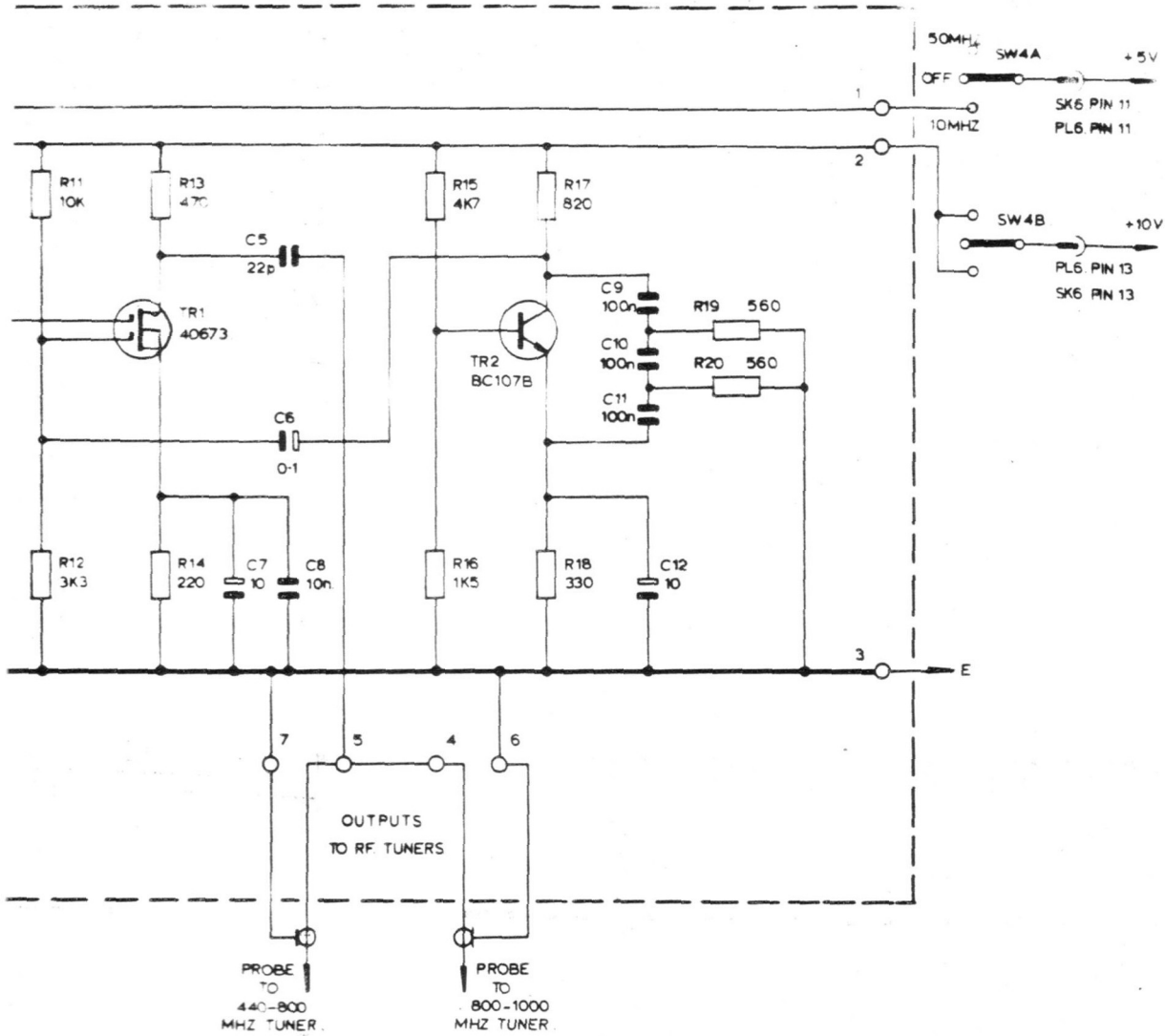

E' ON
RF CHA
PL6
SK6
E
ON FRAM

FROM TUNING POT

1 + 10V FROM RANGE SWITCH 2 440-800 MHZ TUNING UNIT

AERIAL
INPUT 1
SK10

CH1

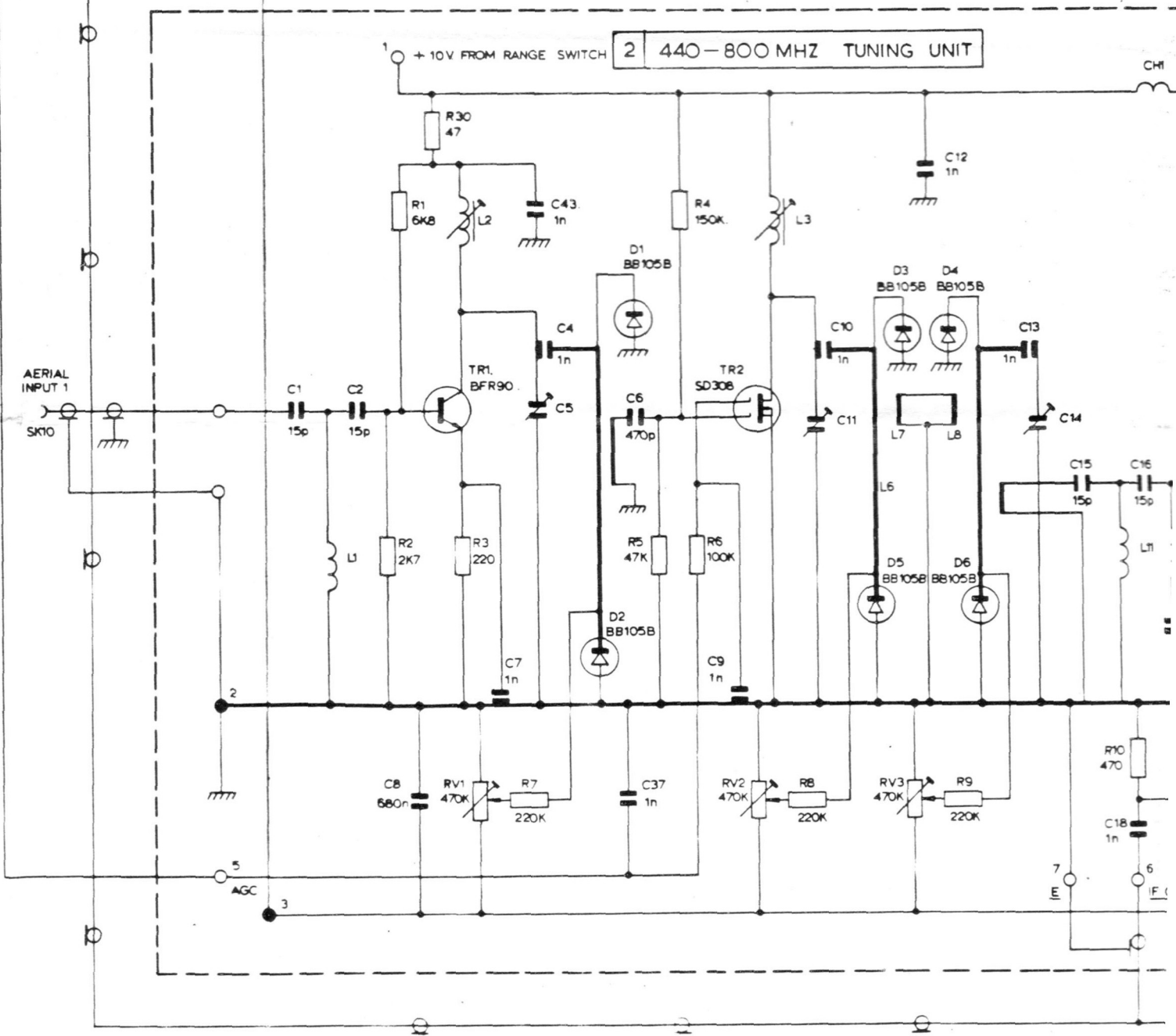

R10
470

C18
1n

7
E

6
F.

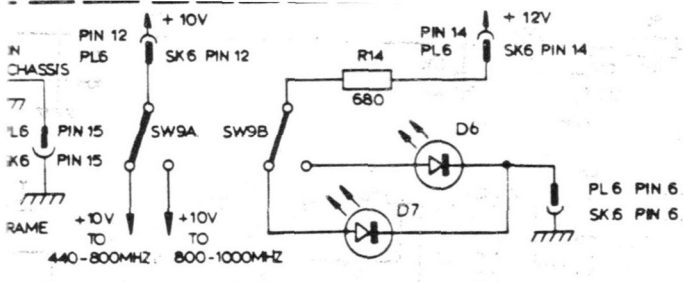

PL8
OSC OUTPUT
TO ± 10 UNIT

+10V

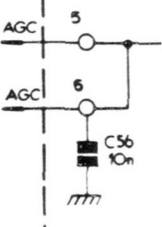
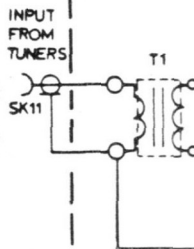
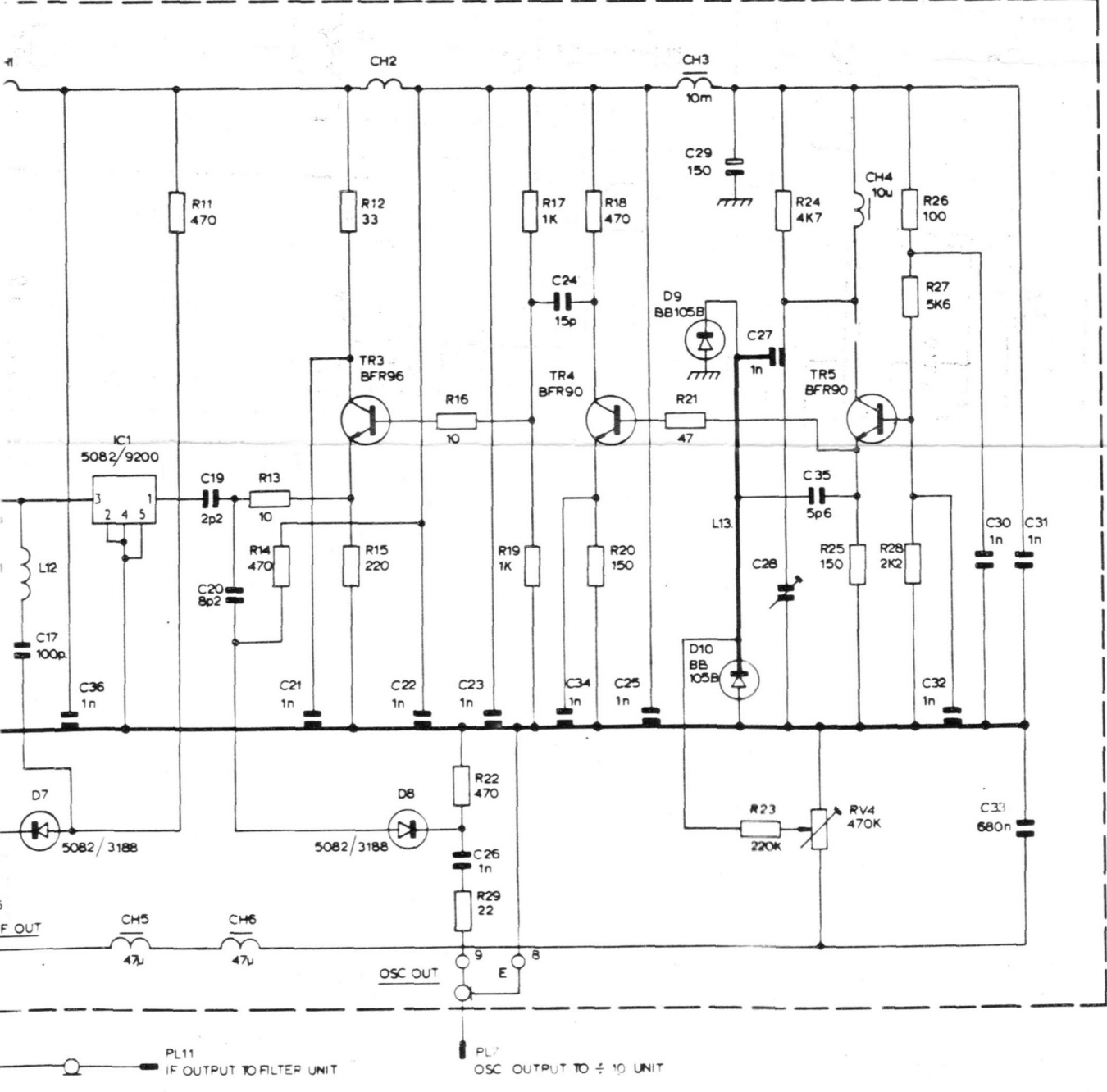

PL11
IF OUTPUT TO FILTER UNIT

PL7
OSC OUTPUT TO ± 10 UNIT

6 SELECTIVITY UNIT

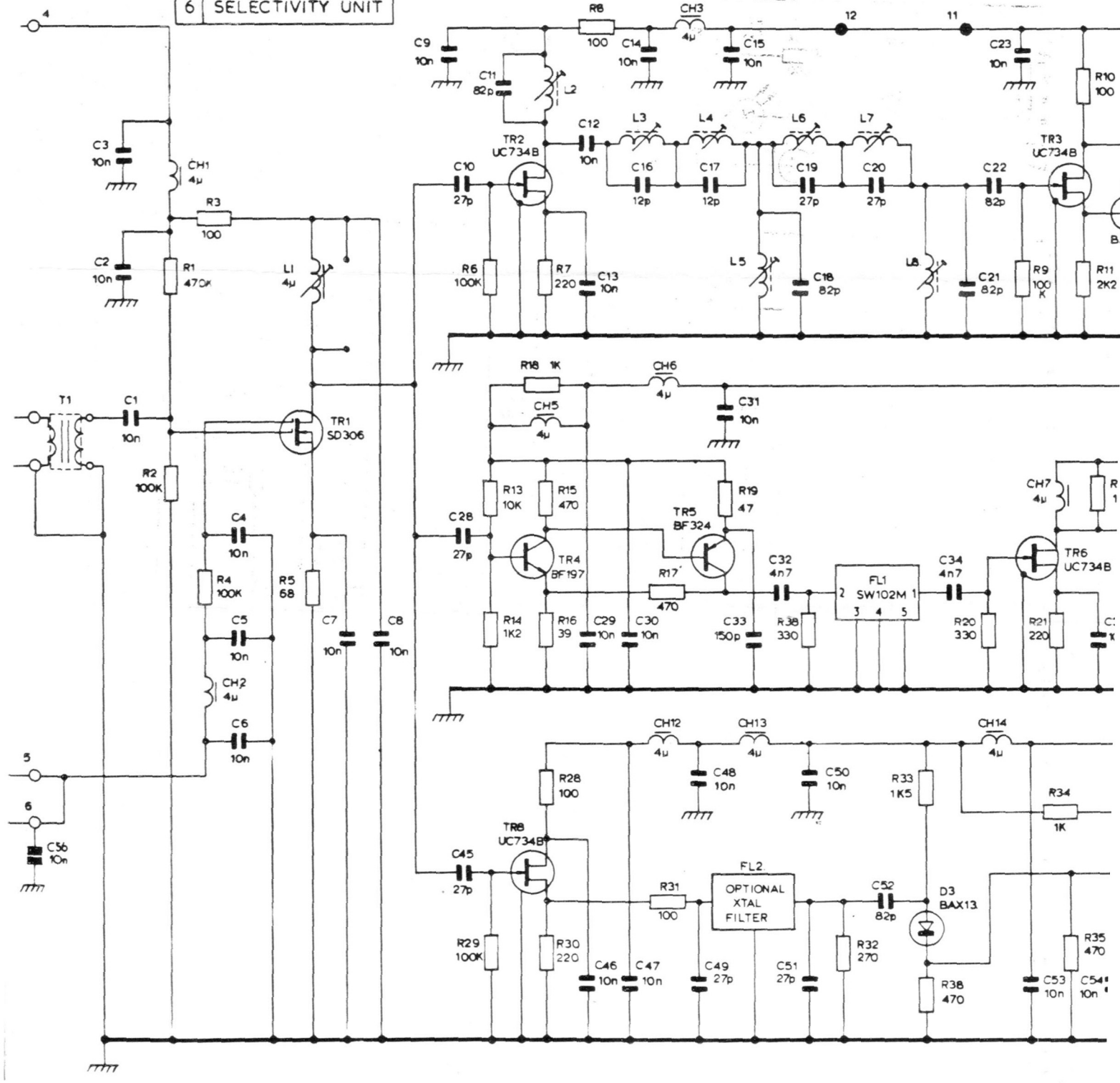

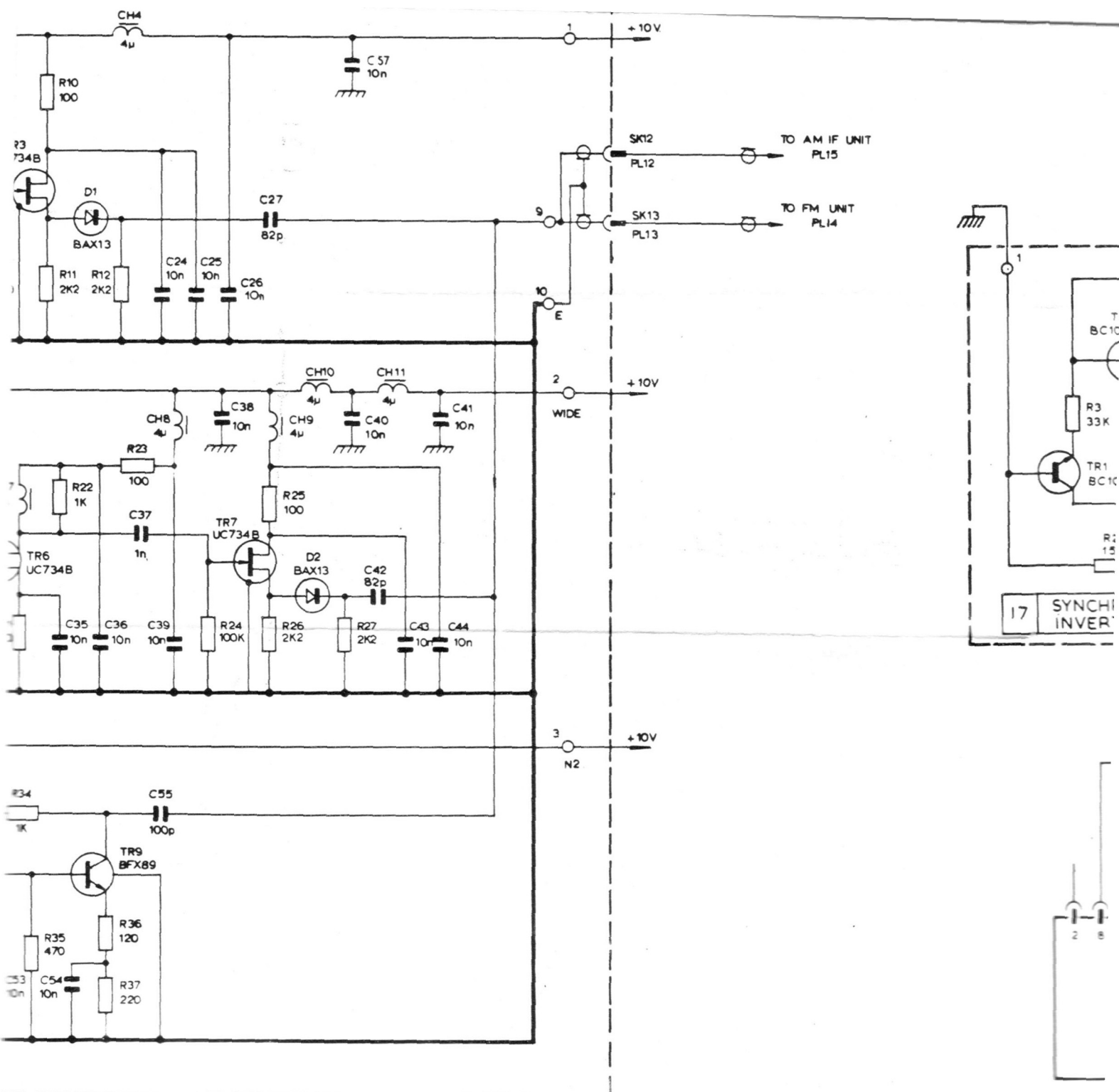

5K7

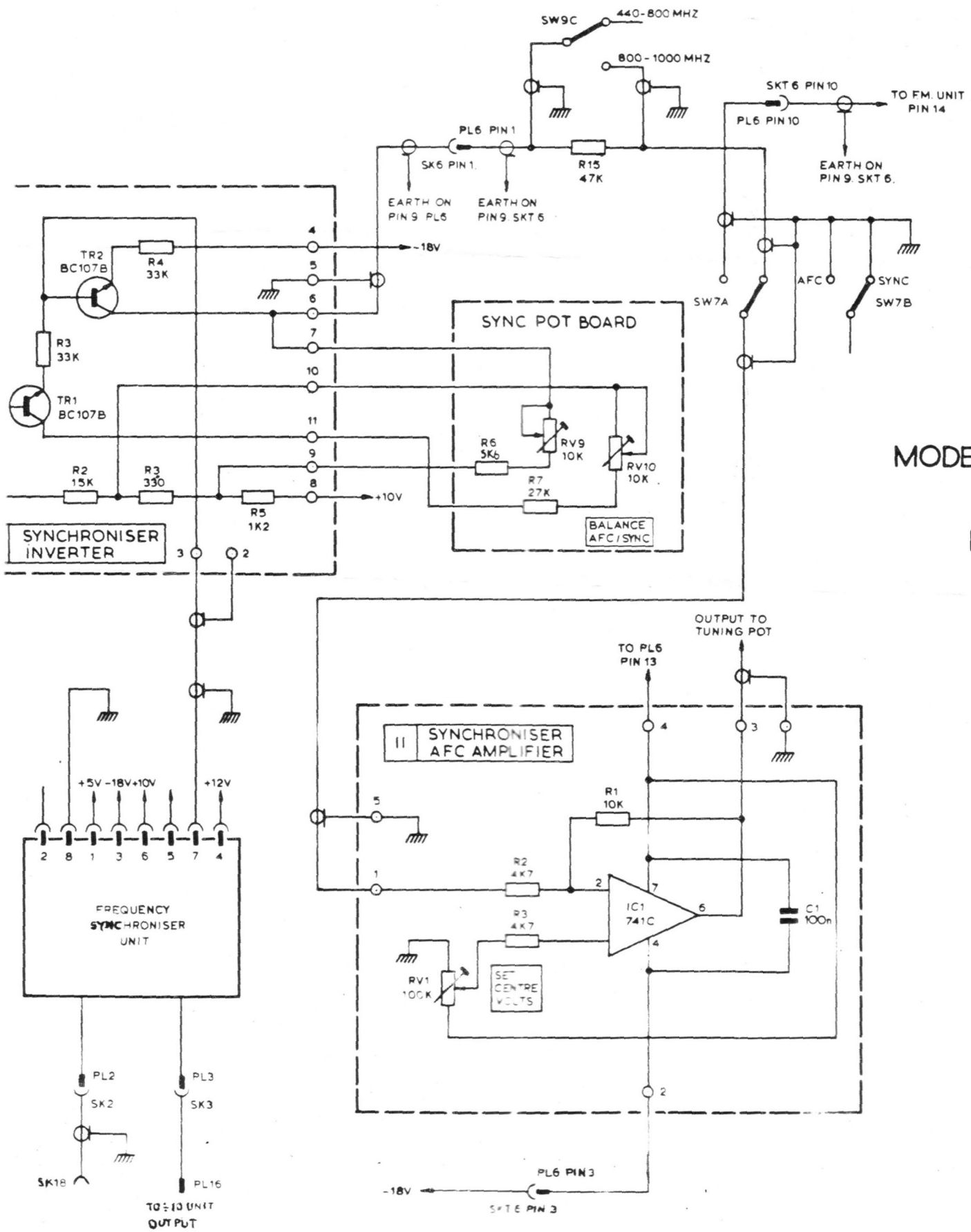

MODEL 1990S
 BP145
 ISSUE 1

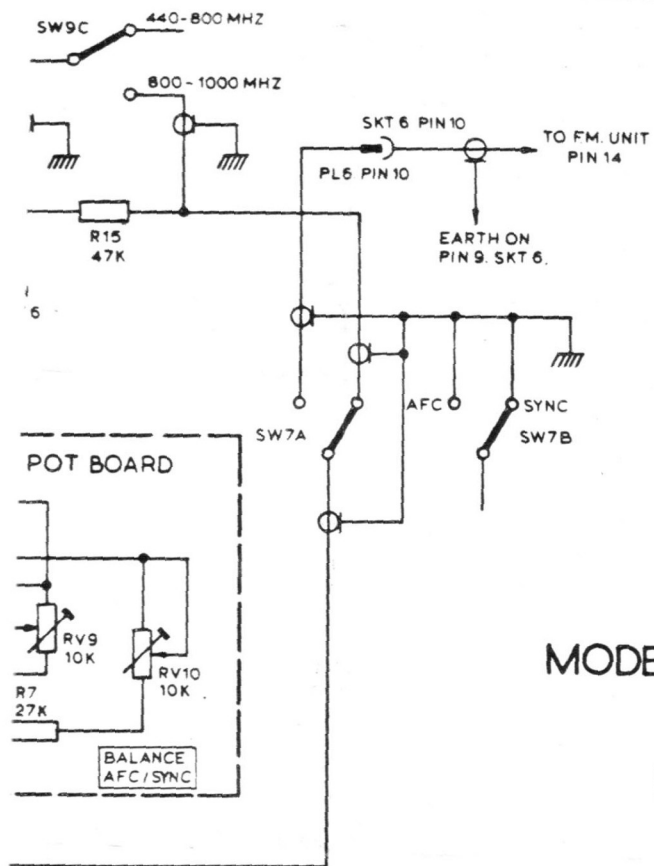

MODEL 1990S PART 2
BP1452
ISSUE 1

